

A large, solid orange circle is centered on a dark gray background. The word "luxor" is written in a bold, black, sans-serif font in the center of the circle.

luxor

SA_bbia

SA_101	17
SA_102	23
SA_103	29
SA_104	35
SA_105	41
SA_106	45

TR_amoto

TR_201	55
TR_202	63
TR_203	69
TR_204	77
TR_205	83
TR_206	89

BR_ezza

BR_301	97
BR_302	103
BR_303	109
BR_304	115
BR_305	121

NU_vole

NU_401	129
NU_402	135
NU_403	141
NU_404	149
NU_405	155
NU_406	161

FINITURE / FINISHES / OBERFLÄCHEN / FINITIONS	167
---	-----

DOVE
L'ARTIGIANALITÀ
INCONTRA
L'ORIZZONTE

Da sempre, le nostre mani plasmano il legno, con la stessa cura con cui il tempo scolpisce i paesaggi che ci circondano. Siamo radicati in un territorio dove i *tr_amenti* infuocati si riflettono sulle montagne, dove la *sa_bbia* della costa conserva il calore del sole e la *br_ezza* marina porta con sé storie di viaggi lontani. Qui, le *nu_vole* si addensano all'improvviso, disegnando nel cielo forme effimere che ispirano la nostra creatività.

Questa terra, con i suoi contrasti e le sue armonie, è il cuore pulsante di ogni nostro progetto. Oggi, dall'incontro tra la tradizione artigianale e una rinnovata visione del design e dell'architettura, nasce il nuovo Luxor: un concept che trasforma l'essenza del territorio in forme contemporanee, dove ogni dettaglio racconta di luce, materia e movimento, esprimendosi in forme architettoniche.

Questo catalogo è un viaggio raccontato attraverso gli elementi che ci circondano e che definiscono il paesaggio e il territorio. Quattro capitoli che raccontano come la natura diventi ispirazione, come l'artigianalità incontri l'innovazione, e come ogni pezzo porti con sé l'essenza del luogo per diventare architettura. Benvenuti nel mondo Luxor.

EN *WHERE CRAFTSMANSHIP
MEETS THE HORIZON.*

For generations, our hands have shaped wood with the same care with which time carves the landscapes around us. We are rooted in a land where blazing sunsets reflect on the mountains, where the sand of the coastline retains the warmth of the sun, and where the sea breeze carries stories of distant journeys. Here, clouds gather suddenly, sketching fleeting forms in the sky that ignite our creativity.

This land, with its contrasts and harmonies, is the beating heart of every one of our projects. Today, from the encounter between artisanal tradition and a renewed vision of design and architecture, the new Luxor is born: a concept that transforms the essence of the territory into contemporary forms, where every detail speaks of light, material, and movement, expressed through architectural shapes.

This catalogue is a journey narrated through the elements that surround us and define the landscape and the territory. Four chapters that reveal how nature becomes inspiration, how craftsmanship meets innovation, and how every piece carries the essence of this place to become architecture. Welcome to the world of Luxor.

DE *WO HANDWERK DEN HORIZONT TRIFFT.*

Seit jeher formen unsere Hände das Holz mit derselben Sorgfalt, mit der die Zeit die Landschaften um uns herum gestaltet. Wir sind in einer Region verwurzelt, in der feurige Sonnenuntergänge sich in den Bergen spiegeln, in der der Sand der Küste die Wärme der Sonne bewahrt und die Meeresbrise Geschichten von fernen Reisen mit sich trägt. Hier verdichten sich plötzlich die Wolken und zeichnen flüchtige Formen an den Himmel, die unsere Kreativität beflügeln.

Dieses Land, mit seinen Kontrasten und Harmonien, ist das pulsierende Herz all unserer Projekte. Heute entsteht aus der Begegnung zwischen handwerklicher Tradition und einer erneuerten Vision von Design und Architektur der neue Luxor: ein Konzept, das das Wesen des Territoriums in zeitgenössische Formen verwandelt, in denen jedes Detail von Licht, Material und Bewegung erzählt — ausgedrückt in architektonischen Gestaltungen.

Dieser Katalog ist eine Reise, erzählt durch die Elemente, die uns umgeben und die Landschaft sowie das Territorium prägen. Vier Kapitel, die zeigen, wie die Natur zur Inspiration wird, wie Handwerkskunst auf Innovation trifft und wie jedes Stück die Essenz dieses Ortes in sich trägt, um Architektur zu werden. Willkommen in der Welt von Luxor.

FR *LÀ OÙ L'ARTISANAT RENCONTRE
L'HORIZON.*

Depuis toujours, nos mains façonnent le bois avec la même attention que le temps met à sculpter les paysages qui nous entourent. Nous sommes enracinés dans une terre où les couchers de soleil enflammés se reflètent sur les montagnes, où le sable de la côte garde la chaleur du soleil et où la brise marine apporte avec elle des histoires de voyages lointains. Ici, les nuages se rassemblent soudainement, dessinant dans le ciel des formes éphémères qui nourrissent notre créativité.

Cette terre, avec ses contrastes et ses harmonies, est le cœur battant de chacun de nos projets. Aujourd'hui, de la rencontre entre la tradition artisanale et une vision renouvelée du design et de l'architecture, naît le nouveau Luxor : un concept qui transforme l'essence du territoire en formes contemporaines, où chaque détail raconte la lumière, la matière et le mouvement, en s'exprimant à travers des géométries architecturales.

Ce catalogue est un voyage raconté à travers les éléments qui nous entourent et qui définissent le paysage et le territoire. Quatre chapitres qui montrent comment la nature devient inspiration, comment l'artisanat rencontre l'innovation, et comment chaque pièce porte en elle l'essence de ce lieu pour devenir architecture. Bienvenue dans l'univers Luxor.

In questo nuovo progetto, la Mobiltesino, con la direzione artistica dell'Architetto Domenico Sfirro ha scelto di superare il concetto tradizionale di arredo per abbracciare una visione più ampia: l'architettura non è solo lo sfondo, ma il dialogo stesso tra oggetto e ambiente.

Il mobile non è pensato come un semplice complemento, ma come un elemento costitutivo dello spazio, una vera e propria estensione architettonica che definisce volumi, ritmi e atmosfere.

L'ispirazione nasce dall'osservazione del territorio e dei suoi elementi naturali che si traducono in forme e proporzioni capaci di modellare l'ambiente. I mobili Luxor non si limitano a occupare uno spazio: lo plasmano, lo arricchiscono, lo rendono unico.

Le linee pulite, i materiali naturali e le palette cromatiche ispirate alla terra, al cielo e all'acqua creano un linguaggio architettonico che trasforma ogni stanza in un luogo pensato, vissuto e sentito.

L'arredo diventa così elemento strutturale che contribuisce a definire l'identità di uno spazio.

IL
MOBILE DIVENTA
ARCHITETTURA

EN *THE FURNITURE BECOMES
ARCHITECTURE.*

In this new project, Mobiltesino — under the artistic direction of Architect Domenico Sfirro — has chosen to move beyond the traditional idea of furniture and embrace a broader vision: architecture is not merely a backdrop, but the very dialogue between object and environment.

The furniture is not conceived as a simple accessory, but as a structural element of the space, a true architectural extension that defines volumes, rhythms and atmospheres.

The inspiration comes from observing the territory and its natural elements, which translate into forms and proportions capable of shaping the environment. Luxor furnishings do not simply occupy a space: they sculpt it, enrich it and make it unique.

Clean lines, natural materials and colour palettes inspired by earth, sky and water create an architectural language that transforms every room into a place that is designed, lived and felt. In this way, furniture becomes a structural component that contributes to defining the identity of a space.

DE *DAS MOBILIAR WIRD ZU ARCHITEKTUR.*

In diesem neuen Projekt hat Mobiltesino — unter der künstlerischen Leitung von Architekt Domenico Sfirro — beschlossen, das traditionelle Konzept von Möbeln zu überwinden und eine umfassendere Vision zu verfolgen: Architektur ist nicht nur eine Kulisse, sondern der eigentliche Dialog zwischen Objekt und Umgebung.

Das Möbelstück wird nicht als einfaches Ergänzungselement gedacht, sondern als konstitutiver Bestandteil des Raumes — eine echte architektonische Erweiterung, die Volumen, Rhythmen und Atmosphären definiert.

Die Inspiration entsteht aus der Beobachtung des Territoriums und seiner natürlichen Elemente, die sich in Formen und Proportionen übersetzen, die den Raum modellieren. Luxor-Möbel begnügen sich nicht damit, einen Raum zu besetzen: Sie formen ihn, bereichern ihn und machen ihn einzigartig.

Klare Linien, natürliche Materialien und Farbpallets, die von Erde, Himmel und Wasser inspiriert sind, schaffen eine architektonische Sprache, die jeden Raum in einen gestalteten, gelebten und empfundenen Ort verwandelt. So wird das Möbelstück zu einem strukturellen Element, das zur Definition der Identität eines Raumes beiträgt.

FR *LE MOBILIER DEVIENT ARCHITECTURE.*

Dans ce nouveau projet, Mobiltesino — sous la direction artistique de l'architecte Domenico Sfirro — a choisi de dépasser le concept traditionnel du mobilier pour adopter une vision plus large : l'architecture n'est pas seulement un décor, mais le dialogue même entre l'objet et son environnement.

Le meuble n'est pas conçu comme un simple complément, mais comme un élément constitutif de l'espace, une véritable extension architecturale qui définit les volumes, les rythmes et les atmosphères.

L'inspiration naît de l'observation du territoire et de ses éléments naturels, qui se traduisent en formes et proportions capables de modeler l'environnement. Les meubles Luxor ne se contentent pas d'occuper un espace : ils le sculptent, l'enrichissent et le rendent unique.

Les lignes épurées, les matériaux naturels et les palettes chromatiques inspirées de la terre, du ciel et de l'eau créent un langage architectural qui transforme chaque pièce en un lieu pensé, vécu et ressenti. Ainsi, le mobilier devient un élément structurel qui contribue à définir l'identité d'un espace.

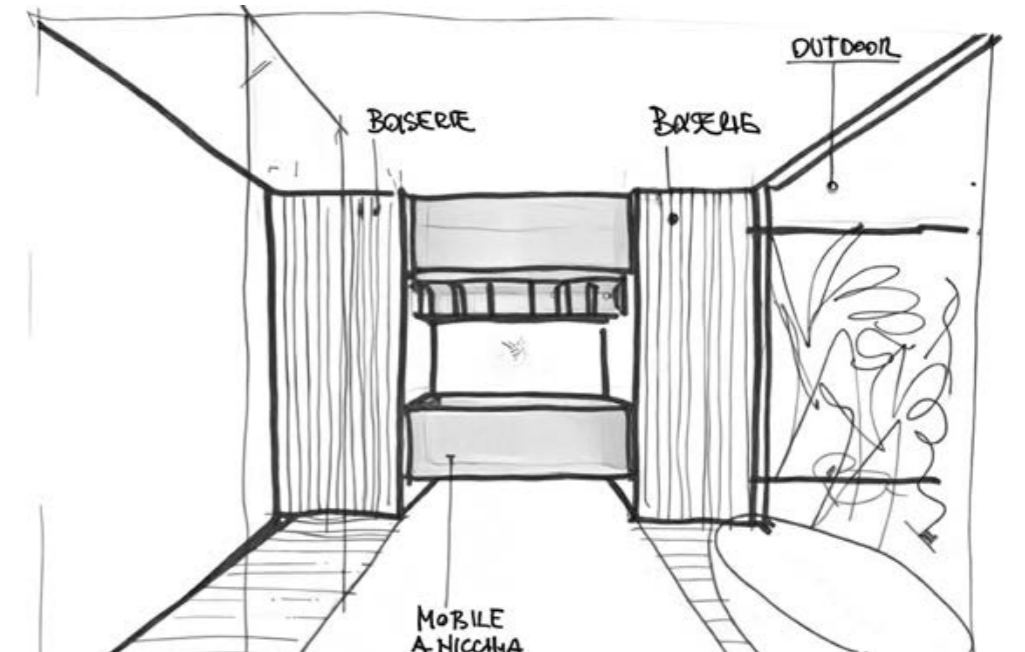
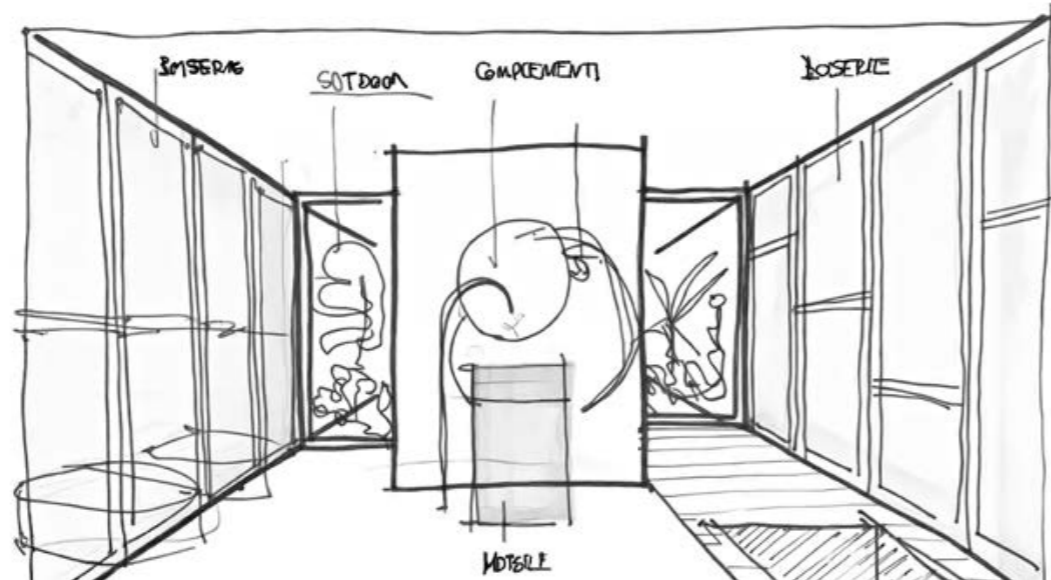
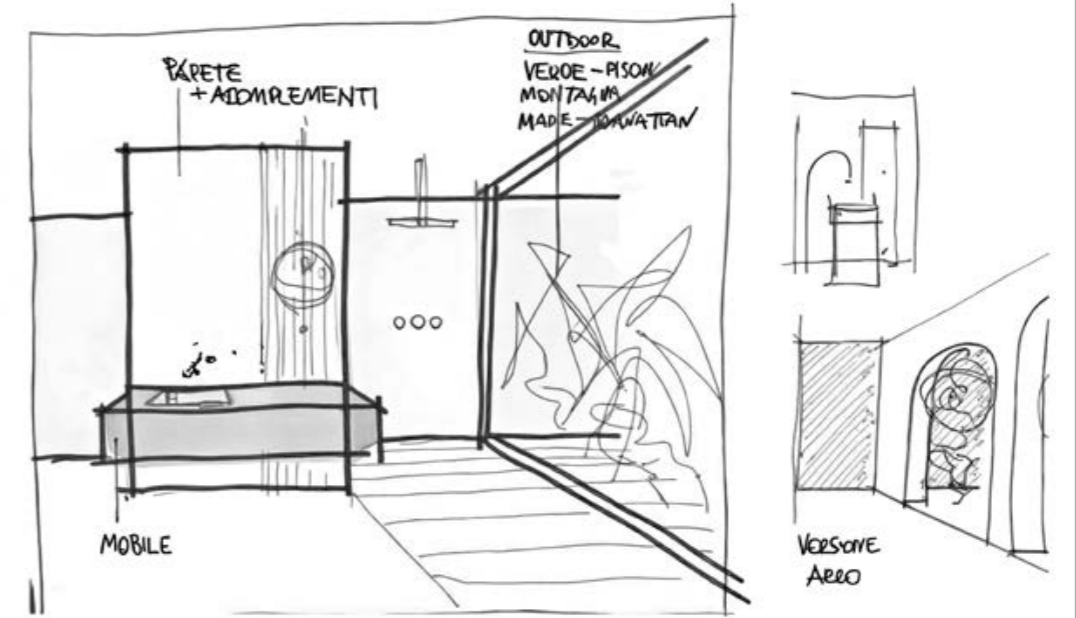
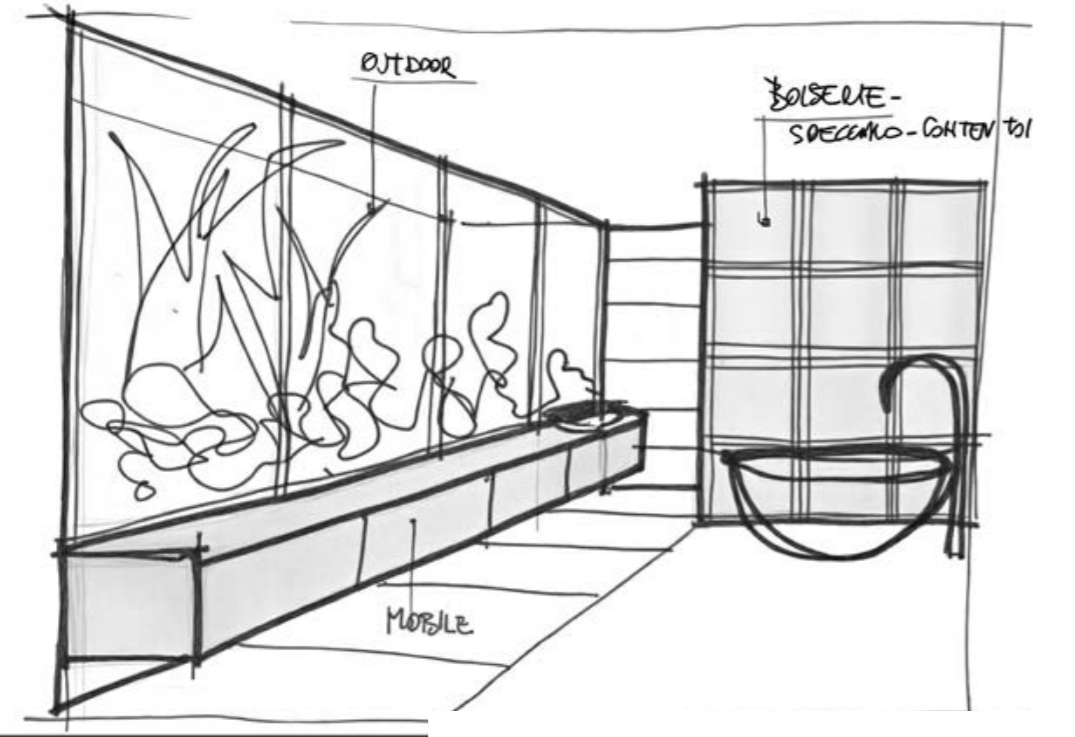
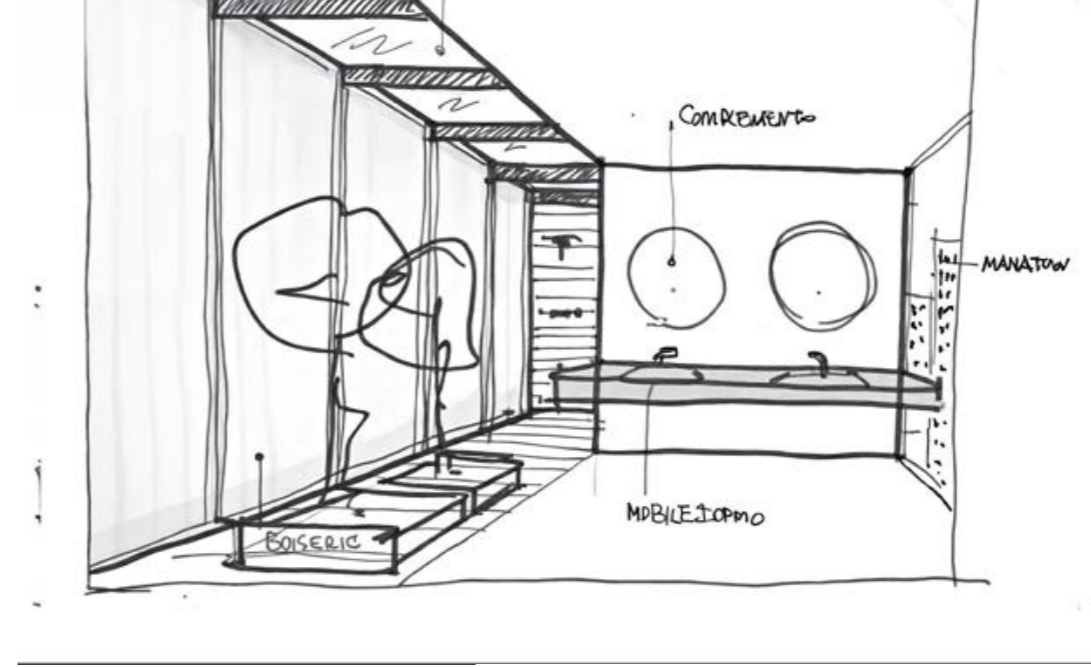
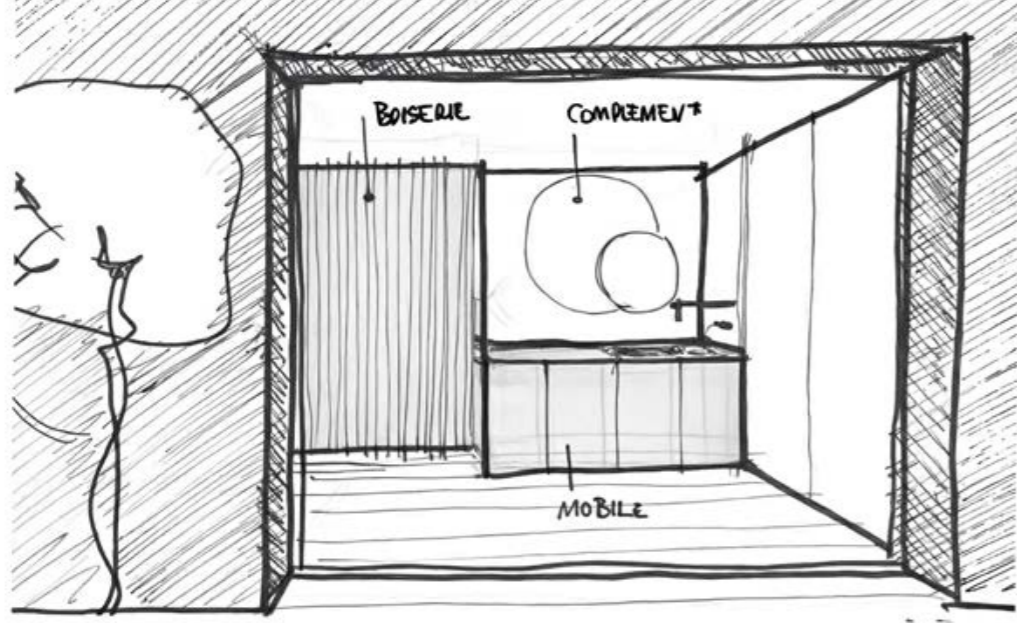

SA_BBIA

COLORE NATURALE - EQUILIBRIO SENZA TEMPO

EN Natural color - Timeless balance,

DE Naturfarbe - Zeitloses Gleichgewicht

FR Couleur naturelle - Équilibre intemporel



SA_101

Mobile Bagno/Laccato opaco Mappamondo

Boiserie/Side Rovere Gold

Top/Piano Solid Color Mappamondo opaco

Lavabo/Sidney Appoggio Solid Color Mappamondo

Specchio/ Stand sospeso con illuminazione.

^{EN} Bathroom Cabinet / matt Lacquer Mappamondo

Boiserie / Side Oak Gold

Top / Solid Color Mappamondo matt

Washbasin / Sidney Countertop Solid Color Mappamondo

Mirror / Stand suspended with lighting.

^{DE} Badezimmermöbel / mattlack Mappamondo

Boiserie / Side Eiche Gold

Waschtischplatte / Solid Color Mappamondo matt

Waschbecken / Sidney Aufsatzbecken Solid Color Mappamondo

Spiegel / Stand hängend mit Beleuchtung.

^{FR} Meuble de Salle de Bain / Laqué mat Mappamondo

Boiserie / Side Chêne Gold

Plan / Solid Color Mappamondo mat

Lavabo / Sidney à poser Solid Color Mappamondo

Miroir / Stand suspendu avec éclairage.

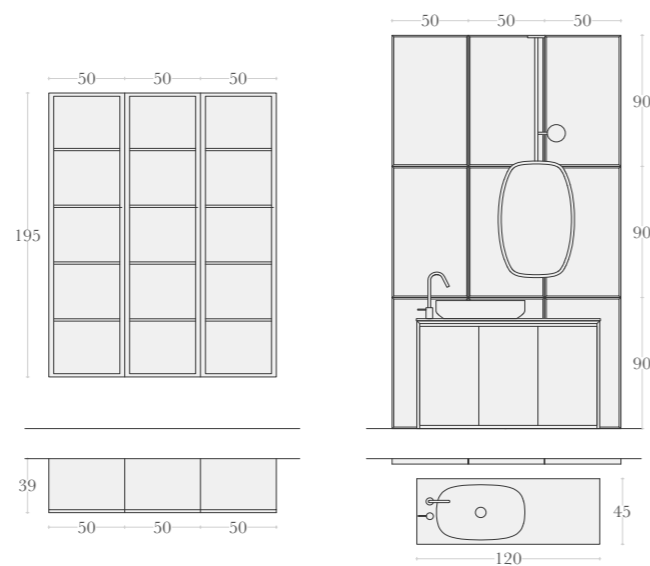







SA_102

Mobile Bagno/ Rovere Gold

Boiserie/Side Rovere Gold

Lavabo/ Appoggio Sidney Solid Bianco opaco

Specchio/ Sole Retroilluminato

Lampada/Thula parete.

^{EN} Bathroom Cabinet / Rovere Gold

Boiserie / Side Rovere Gold

Washbasin / Appoggio Sidney Solid White matt

Mirror / Sole backlit

Lamp / Thula wall.

^{DE} Badezimmermöbel / Rovere Gold

Boiserie / Side Rovere Gold

Waschbecken / Appoggio Sidney Solid Weiß matt

Spiegel / Sole mit Hinterleuchtung

Lampe / Thula wand.

^{FR} Meuble de Salle de Bain / Rovere Gold

Boiserie / Side Rovere Gold

Lavabo / Appoggio Sidney Solid White mat

Miroir / Sole rétroéclairé

Lampe / Thula murale.

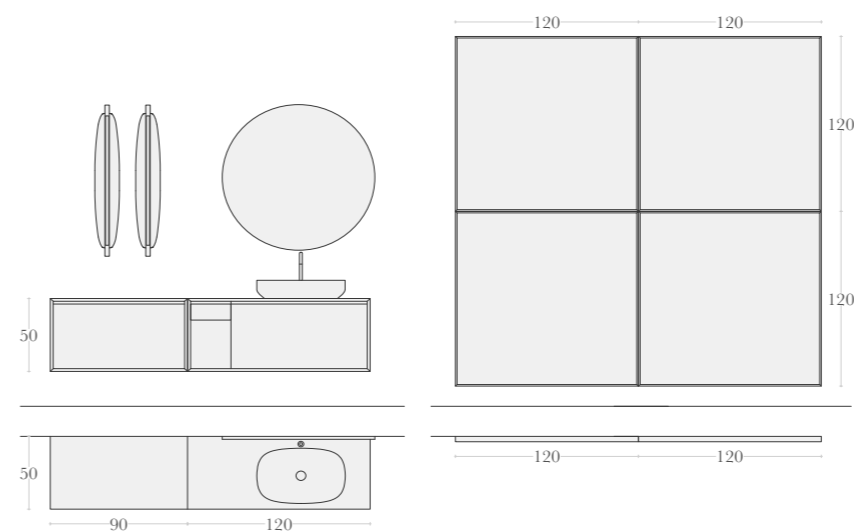







SA_103

Mobile Bagno/ Rovere Gold

Boiserie/ Side Rovere Gold

Top/Piano Gres Travertino Bianco

Lavabo/ Appoggio Class Bronze

Specchio/ Avatar contenitore.

^{EN} Bathroom Cabinet / Rovere Gold

Boiserie / Side Rovere Gold

Top / Gres Travertino Bianco

Washbasin / Appoggio Class Bronze

Mirror / Avatar cabinet.

^{DE} Badezimmermöbel / Rovere Gold

Boiserie / Side Rovere Gold

Waschtischplatte / Gres Travertino Bianco

Waschbecken / Appoggio Class Bronze

Spiegel / Avatar Schrank.

^{FR} Meuble de Salle de Bain / Rovere Gold

Boiserie / Side Rovere Gold

Plan / Gres Travertino Bianco

Lavabo / Appoggio Class Bronze

Miroir / Avatar caisson.

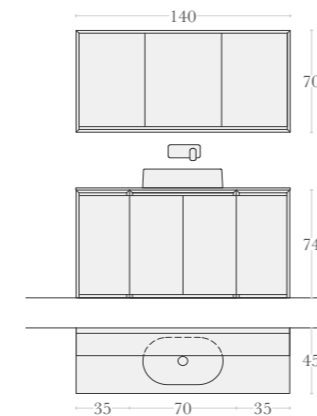





SA_104

Mobile Bagno/ Rovere Gold

Boiserie/Side Rovere Gold

Lavabo/ Appoggio Domo Marmo Fior di Pesco

Specchio/Side

Lampada/ Osman sospensione - Osman parete.

^{EN} Bathroom Cabinet/ Rovere Gold

Boiserie/Side Rovere Gold

Washbasin/ Countertop Domo Fior di Pesco Marble

Mirror/Side.

Lamp/ Osman Pendant – Osman Wall.

^{DE} Badezimmermöbel/ Rovere Gold

Boiserie/Side Rovere Gold

Waschbecken/ Aufsatz Domo Marmor Fior di Pesco

Spiegel/Side.

Lampe/ Osman Pendelleuchte – Osman Wandlampe.

^{FR} Meuble Salle de Bain/ Rovere Gold

Boiserie/Side Rovere Gold

Lavabo/ À Poser Domo Marbre Fior di Pesco

Miroir/Side

Lampe/ Osman Suspension – Osman Applique.

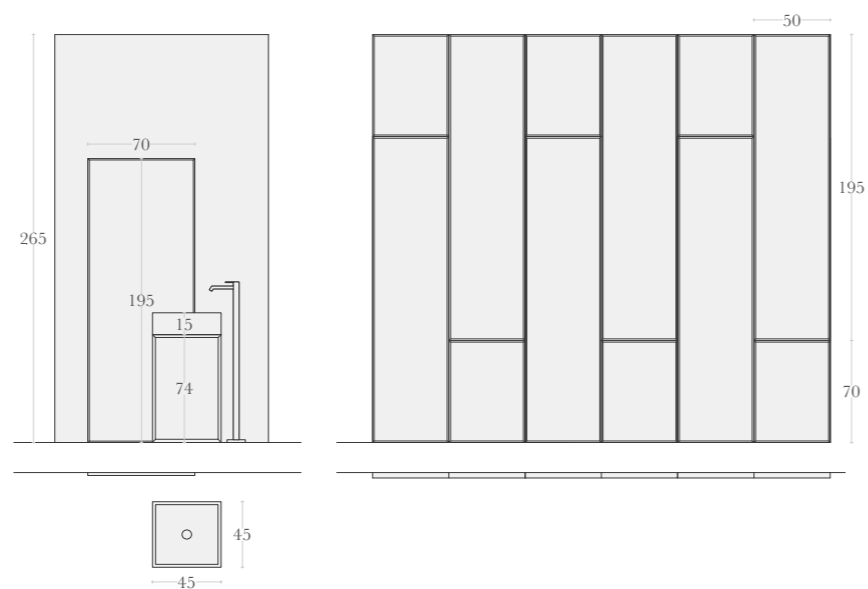





SA_105

Mobile Bagno/Rovere Gold
 Boiserie/Side Rovere Gold
 Top/Piano Ocritech opaco
 Lavabo/ Appoggio Class Bronze
 Lampada/Nastro sospensione.

^{EN} Bathroom Cabinet/ Rovere Gold
 Boiserie/Side Rovere Gold
 Top/ Countertop matt Ocritech
 Washbasin/ Class Countertop Bronze
 Lamp/ Nastro Pendant.

^{DE} Badezimmermöbel/ Rovere Gold
 Boiserie/Side Rovere Gold
 Top/ Platte Ocritech matt
 Waschbecken/ Class Aufsatz Bronze
 Lampe/ Nastro Pendelleuchte.

^{FR} Meuble Salle de Bain/ Rovere Gold
 Boiserie/Side Rovere Gold
 Top/ Plateau Ocritech mat
 Lavabo/ Class À Poser Bronze
 Lampe/ Nastro Suspension.

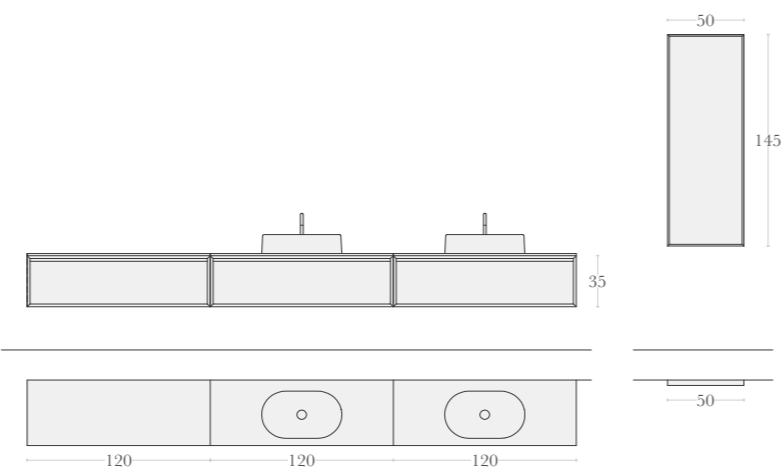





SA_106

Mobile Bagno/Rovere Gold

Top/integrale Solid Bianco vasca Plaza

Specchio/ Stand sospeso con illuminazione.

^{EN} Bathroom Cabinet / Rovere Gold

Top / integrale Solid Bianco Plaza basin

Mirror / Stand suspended with lighting.

^{DE} Badezimmermöbel / Rovere Gold

Waschtischplatte / integrale Solid Bianco Plaza-Becken

Spiegel / Stand hängend mit Beleuchtung.

^{FR} Meuble de Salle de Bain / Rovere Gold

Plan / intégrale Solid Bianco vasque Plaza

Miroir / Stand suspendu avec éclairage.

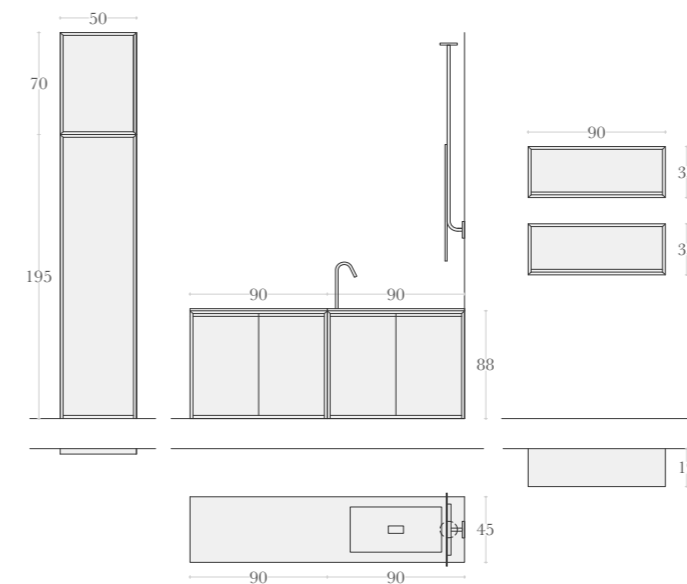







TR_amoto

L'ELEGANZA DEL COLORE CHE AVVOLGE

EN The elegance of color that embraces

DE Die eleganz der farbe, die umhüllt

FR L'élégance de la couleur qui enveloppe



TR_201

Mobile Bagno/Laccato opaco Cioccolato

Top/Piano Gres Terra di Pompei

Lavabo/ Appoggio Manta Gres Terra di Pompei

Specchio/Pulse Retroilluminato

Lampada/ Nabila sospensione.

^{EN} Bathroom Cabinet/ matt Lacquered Chocolate
 Top/ Countertop Pompeii Earth Stoneware
 Washbasin/ Manta Countertop Pompeii Earth Stoneware
 Mirror/ Pulse Backlit
 Lamp/ Nabila Pendant.

^{DE} Badezimmermöbel/ matt Lackiert Schokolade
 Top/ Platte Feinsteinzeug Terre di Pompei
 Waschbecken/ Manta Aufsatz Feinsteinzeug Terre di Pompei
 Spiegel/ Pulse Hinterleuchtet
 Lampe/ Nabila Pendelleuchte.

^{FR} Meuble Salle de Bain/ Laqué mat Chocolat
 Top/ Plateau Grès Terre de Pompéi
 Lavabo/ Manta À Poser Grès Terre de Pompéi
 Miroir/ Pulse Rétroéclairé
 Lampe/ Nabila Suspension.

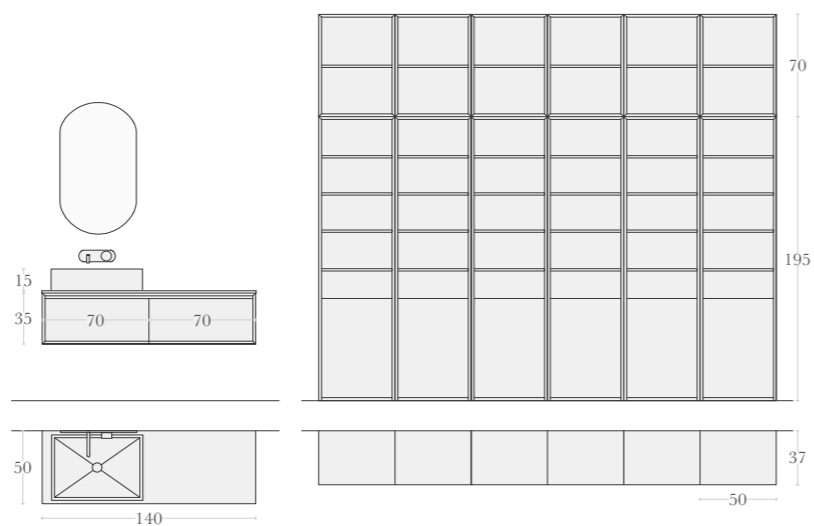









TR_202

Mobile Bagno/Laccato opaco Mocha Mousse
 Top/Integrale Vetro satinato Seppia
 Specchio/Matrix illuminazione integrata.

^{EN} Bathroom Cabinet/ matt Lacquered Mocha Mousse

Top/ Integrated Satin Sepia Glass

Mirror/ Matrix with Integrated Lighting.

^{DE} Badezimmermöbel/ matt Lackiert Mocha Mousse

Top/ Integriert Satiniertes Sepia-Glas

Spiegel/ Matrix mit Integrierter Beleuchtung.

^{FR} Meuble Salle de Bain/ Laqué mat Mocha Mousse

Top/ Intégré Verre Satiné Sépia

Miroir/ Matrix avec Éclairage Intégré.

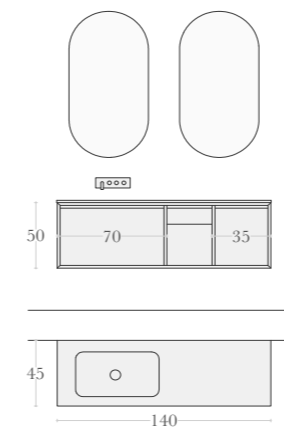





TR_203

Mobile Bagno/ Noce Canaletto

Cassetto Laccato lucido Rosso Vino

Boiserie/Light Noce Canaletto Donegal

Specchio/Alba Retroilluminato

Lavabo/ Appoggio Class Fumè

Lampada/Osman sospensione.

EN Bathroom Cabinet / Noce Canaletto
 Drawer / Glossy Lacquer Rosso Vino
 Boiserie / Light Noce Canaletto Donegal
 Mirror / Alba backlit
 Washbasin / Appoggio Class Fumè
 Lamp / Osman suspension.

DE Badezimmermöbel / Noce Canaletto
 Schublade / Glanzlack Rosso Vino
 Boiserie / Light Noce Canaletto Donegal
 Spiegel / Alba mit Hinterleuchtung
 Waschbecken / Appoggio Class Fumè
 Lampe / Osman Hängeleuchte.

FR Meuble de Salle de Bain / Noce Canaletto
 tiroir / Laqué Brillant Rosso Vino
 Boiserie / Light Noce Canaletto Donegal
 Miroir / Alba rétroéclairé
 Lavabo / Appoggio Class Fumè
 Lampe / Osman suspension.

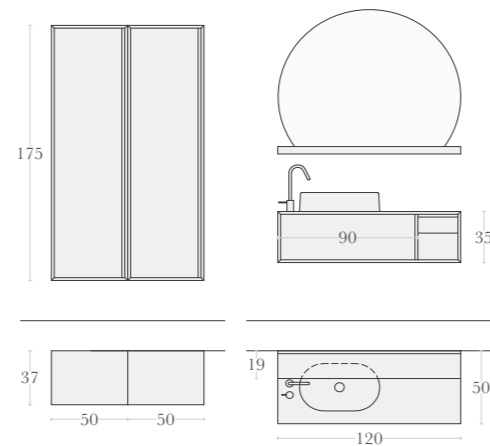













TR_205
 Mobile /Laccato opaco Mocha Mousse

EN Cabinet/ matt Lacquered Mocha Mousse.

DE Möbel/ matt Lackiert Mocha Mousse.

FR Meuble/ Laqué mat Mocha Mousse.

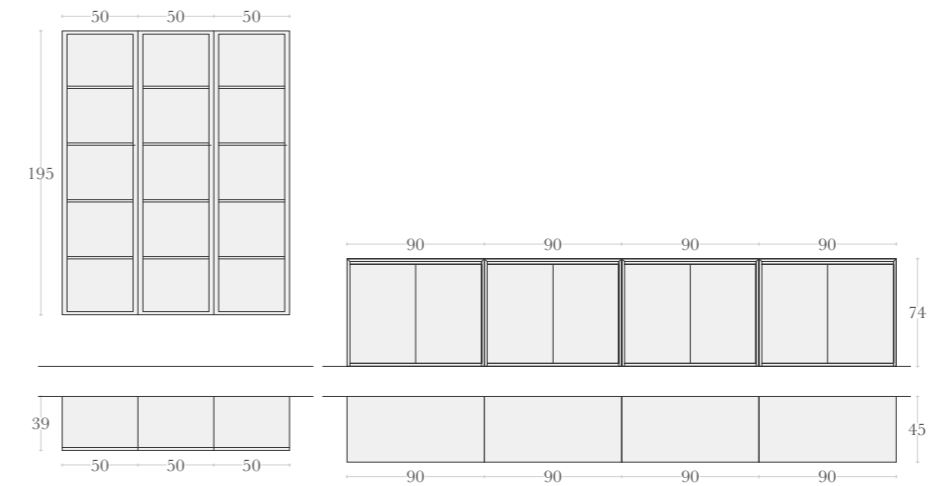





TR_206

Mobile Bagno/Noce Canaletto frontale Barcode

Boiserie/Light Noce Canaletto Barcode

Specchio/ Up – Turn

Lavabo/Semincasso Skin Solid Color Mocha Mousse

Lampada/Thula parete.

^{EN} Bathroom Cabinet / Noce Canaletto front Barcode
Boiserie / Light Noce Canaletto Barcode
Mirror / Up – Turn
Washbasin / Semincasso Skin Solid Color Mocha Mousse
Lamp / Thula wall.

^{DE} Badezimmermöbel / Noce Canaletto front Barcode
Boiserie / Light Noce Canaletto Barcode
Spiegel / Up – Turn
Waschbecken / Semincasso Skin Solid Color Mocha Mousse
Lampe / Thula wand.

^{FR} Meuble de Salle de Bain / Noce Canaletto frontal Barcode
Boiserie / Light Noce Canaletto Barcode
Miroir / Up – Turn
Lavabo / Semincasso Skin Solid Color Mocha Mousse
Lampe / Thula murale.

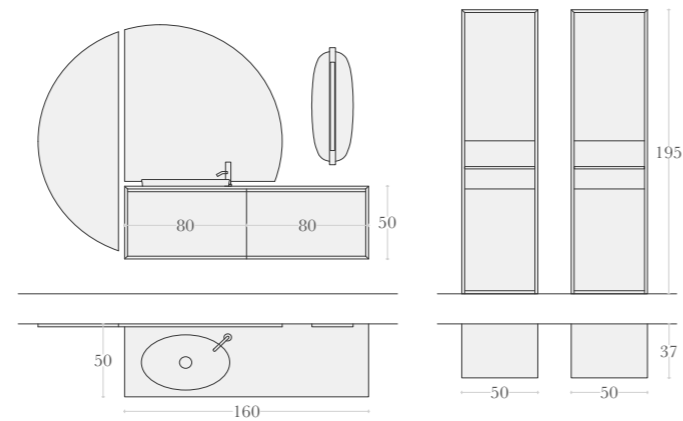





BR_ezza

FRESCHEZZA LEGGERA CHE RIGENERA

EN Light freshness that regenerates.

DE Leichte frische, die regeneriert.

FR Fraîche légèreté qui régénère.





BR_301

Mobile Bagno/Rovere Sand frontale Millerighe
 Boiserie/Side Rovere Sand Millerighe
 Top/Integrale Solid Bianco opaco Vasca Plaza
 Specchio/Side
 Lampada/Over sospesa.

^{EN} Bathroom Cabinet / Rovere Sand front Millerighe

Boiserie / Side Rovere Sand Millerighe

Top / Integrale Solid Bianco Opaco Plaza basin

Mirror / Side

Lamp / Over suspended.

^{DE} Badezimmermöbel / Rovere Sand front Millerighe

Boiserie / Side Rovere Sand Millerighe

Waschtischplatte / Integrale Solid Bianco Opaco Plaza-Becken

Spiegel / Side

Lampe / Over hängend.

^{FR} Meuble de Salle de Bain / Rovere Sand frontal Millerighe

Boiserie / Side Rovere Sand Millerighe

Plan / Intégrale Solid Bianco Opaco vasque Plaza

Miroir / Side

Lampe / Over suspendue.

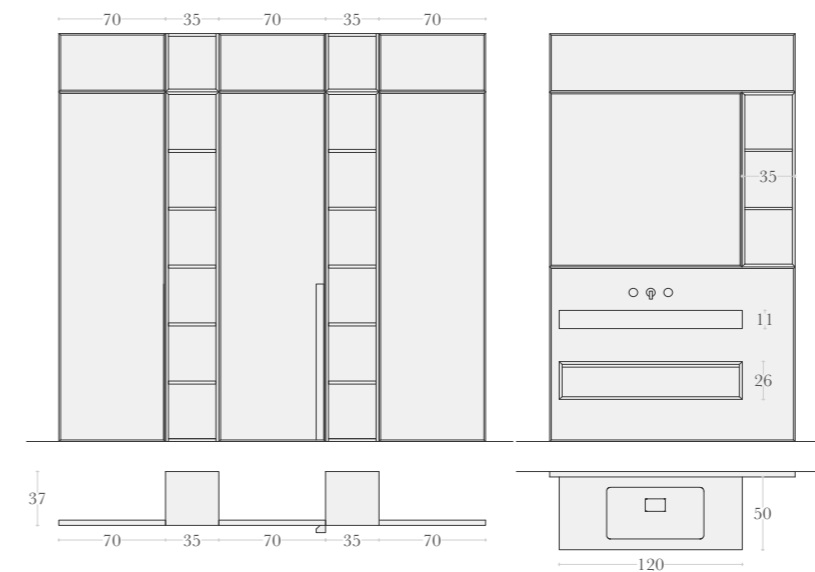





BR_302**Mobile Bagno/Laccato opaco Cedar Blue****Rivestimento frontale Vetro Tweed Cedar Blue****Wallpaper/Tweed Cedar Blue fondo bianco****Top/ Integrale Solid Bianco opaco Vasca Nio****Specchio/Avatar Contenitore Laccato opaco Bianco**^{EN} Bathroom Cabinet / matt Lacquer Cedar Blue

Front covering / Glass Tweed Cedar Blue

Wallpaper / Tweed Cedar Blue white background

Top / Integrale Solid Bianco Opaco Nio basin

Mirror / Avatar cabinet matt Lacquer White.

^{DE} Badezimmermöbel / mattlack Cedar Blue

Frontverkleidung / Glas Tweed Cedar Blue

Tapete / Tweed Cedar Blue weißer Hintergrund

Waschtischplatte / Integrale Solid Bianco Opaco Nio-Becken

Spiegel / Avatar Schrank mattlack Weiß.

^{FR} Meuble de Salle de Bain / Laqué mat Cedar Blue

Revêtement frontal / Verre Tweed Cedar Blue

Papier Peint / Tweed Cedar Blue fond blanc

Plan / Intégrale Solid Bianco Opaco vasque Nio

Miroir / Avatar caisson Laqué mat Blanc.

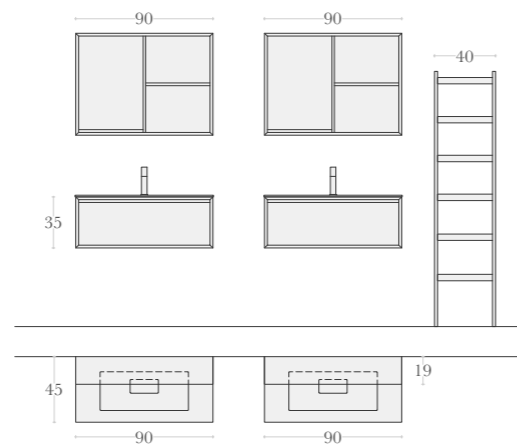







BR_303

Mobile Bagno/Laccato opaco Sabbia

Top/Integrale Solid Bianco opaco Vasca Nio

Specchio/Filo

Lampada/Riga.

^{EN} Bathroom Cabinet / matt Lacquer Sabbia

Top / Integrale Solid Bianco Opaco Nio basin

Mirror / Filo

Lamp / Riga.

^{DE} Badezimmermöbel / mattlack Sabbia

Waschtischplatte / Integrale Solid Bianco Opaco Nio-Becken

Spiegel / Filo

Lampe / Riga.

^{FR} Meuble de Salle de Bain / Laqué mat Sabbia

Plan / Intégrale Solid Bianco Opaco vasque Nio

Miroir / Filo

Lampe / Riga.

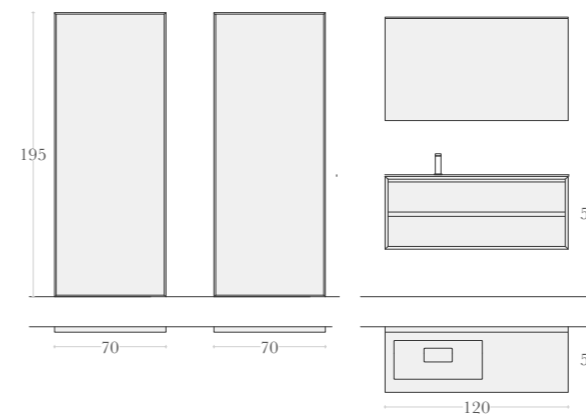





BR_304

Mobile Bagno/Rovere Sand frontale Millerighe

Boiserie/Light Rovere Sand Millerighe

Top/Integrale scatola Ocritech opaco Vasca Place

Specchio/Soft retroilluminato

Lampada/ Osman sospensione.

^{EN} Bathroom Cabinet / Rovere Sand front millerighe

Boiserie / Light Rovere Sand Millerighe

Top / Integrale boxed Ocritech matt Place basin

Mirror / Soft backlit

Lamp / Osman suspended.

^{DE} Badezimmermöbel / Rovere Sand front Millerighe

Boiserie / Light Rovere Sand millerighe

Waschtischplatte / Integrale Kasten Ocritech matt Place-Becken

Spiegel / Soft mit Hinterleuchtung

Lampe / Osman hängend.

^{FR} Meuble de Salle de Bain / Rovere Sand frontal Millerighe

Boiserie / Light Rovere Sand millerighe

Plan / Intégrale caisson Ocritech mat vasque Place

Miroir / Soft rétroéclairé

Lampe / Osman suspendue.

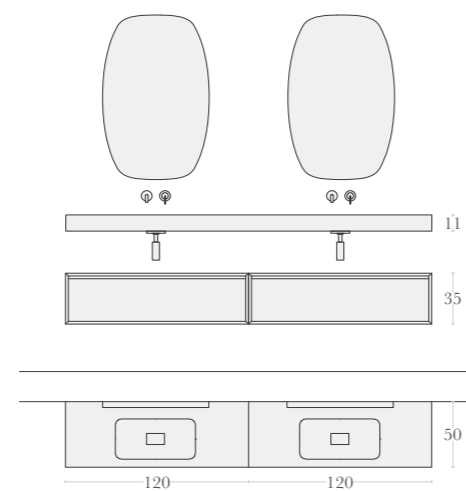







BR_305

Mobile Bagno/Laccato opaco Verde Aloe frontale Barcode

Mobile/ Rovere Sand

Wallpaper/Tweed Bianco fondo Verde Aloe

Top/Integrale Ocritech opaco Vasca Zero

Specchio/ Sasso retroilluminato.

^{EN} Bathroom Cabinet / matt Lacquer Verde Aloe front Barcode

Cabinet / Rovere Sand

Wallpaper / Tweed Bianco Verde Aloe background

Top / Integrale Ocritech matt Zero basin

Mirror / Sasso backlit.

^{DE} Badezimmermöbel / mattlack Verde Aloe front Barcode

Möbel / Rovere Sand

Tapete / Tweed Bianco Hintergrund Verde Aloe

Waschtischplatte / Integrale Ocritech matt Zero-Becken

Spiegel / Sasso mit Hinterleuchtung.

^{FR} Meuble de Salle de Bain / Laqué mat Verde Aloe frontal Barcode

Meuble / Rovere Sand

Papier Peint / Tweed Bianco fond Verde Aloe

Plan / Intégrale Ocritech mat vasque Zero

Miroir / Sasso rétroéclairé.

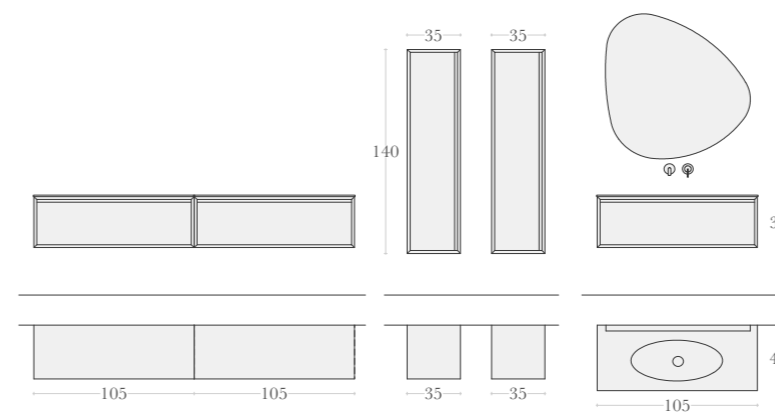





NU_vole

DOVE LA FORMA INCONTRA LA QUIETE

EN Where form meets calm.

DE Wo form auf ruhe trifft.

FR Là où la forme rencontre le calme.



NU_401

Mobile Bagno/Rovere Grey Frontale Millerighe

Boiserie/Light Rovere Grey Millerighe

Top/Integrale Gres Diamond Cream Vasca Icona

Specchio/Filo

Lampada/King specchio

Thula parete – Nastro sospensione.

^{EN} Bathroom Cabinet / Rovere Grey front Millerighe

Boiserie / Light Rovere Grey Millerighe

Top / Integrale Gres Diamond Cream Icona basin

Mirror / Filo

Lamp / King mirror

Thula wall – Nastro suspended.

^{DE} Badezimmermöbel / Rovere Grey front Millerighe

Boiserie / Light Rovere Grey Millerighe

Waschtischplatte / Integrale Gres Diamond Cream Icona-Becken

Spiegel / Filo

Lampe / King spiegel

Thula wand – Nastro hängend.

^{FR} Meuble de Salle de Bain / Rovere Grey frontal Millerighe

Boiserie / Light Rovere Grey Millerighe

Plan / Intégrale Gres Diamond Cream vasque Icona

Miroir / Filo

Lampe / King miroir

Thula murale – Nastro suspendue.

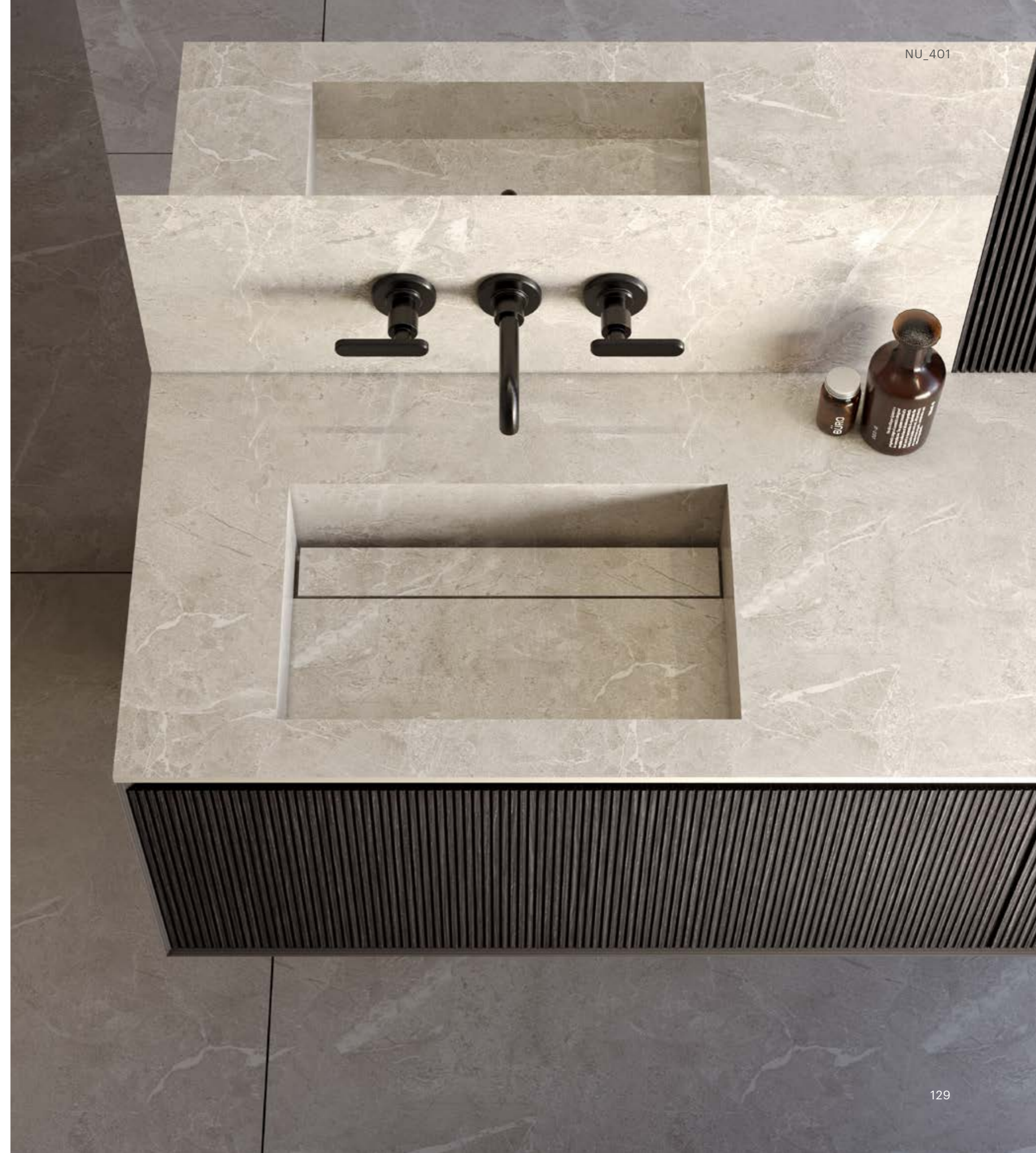
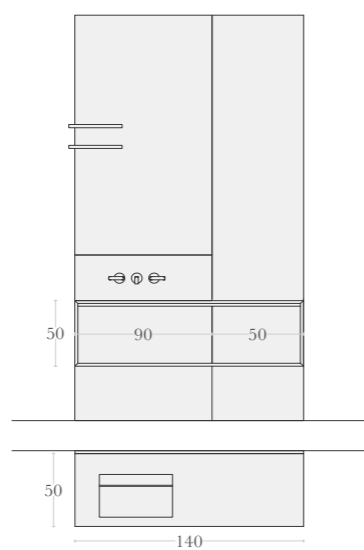







NU_402

Mobile Bagno/Rovere Termocotto

Boiserie/Light Rovere Termocotto Donegal

Top/Integrale Marmo Verde Alpi Vasca Hall

Specchio/Sole Retroilluminato.

^{EN} Bathroom Cabinet / Rovere Termocotto
Boiserie / Light Rovere Termocotto Donegal
Top / Integrale Marmo Verde Alpi Hall basin
Mirror / Sole backlit.

^{DE} Badezimmermöbel / Rovere Termocotto
Boiserie / Light Rovere Termocotto Donegal
Waschtischplatte / Integrale Marmo Verde Alpi Hall-Becken
Spiegel Sole mit Hintergrundbeleuchtung.

^{FR} Meuble de Salle de Bain / Rovere Termocotto
Boiserie / Light Rovere Termocotto Donegal
Plan / Intégrale Marmo Verde Alpi vasque Hall
Miroir / Sole rétroéclairé.

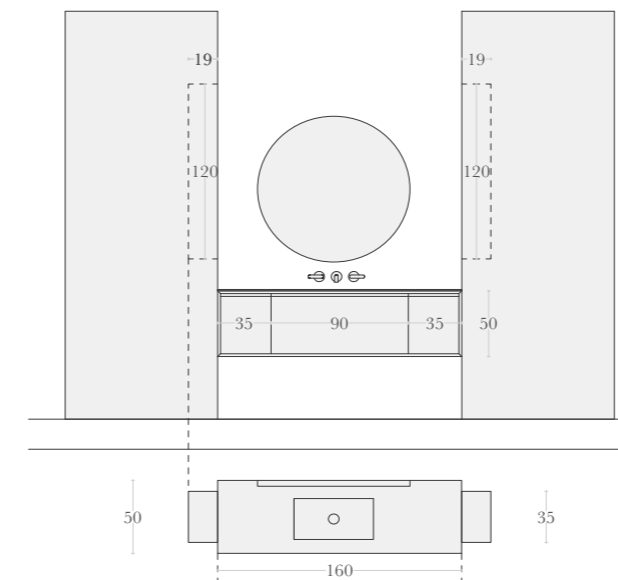





NU_403

Mobile Bagno/Rovere Seppia

Rivestimento frontale vetro Plissé Grigio Efeso

Boiserie/Side Rovere Seppia Frontale Vetro Plissé Grigio Efeso

Top/Integrale Scatolato Gres Nero Vasca Icona

Specchio/Side

Lampada/Gordon soffitto.

^{EN} Bathroom Cabinet / Rovere Seppia
 Glass covering front / Plissé Grigio Efeso
 Boiserie / Side Rovere Seppia front Glass Plissé Grigio Efeso
 Top / Integrale boxed Gres Nero Icona basin
 Mirror / Side
 Lamp / Gordon ceiling.

^{DE} Badezimmermöbel / Rovere Seppia
 Glasverkleidung front / Plissé Grigio Efeso
 Boiserie / Side Rovere Seppia front Glas Plissé Grigio Efeso
 Waschtischplatte / Integrale Kasten Gres Nero Icona-Becken
 Spiegel / Side
 Lampe / Gordon decke.

^{FR} Meuble de Salle de Bain / Rovere Seppia
 Revêtement verre frontal / Plissé Grigio Efeso
 Boiserie / Side Rovere Seppia frontal Verre Plissé Grigio Efeso
 Plan / Intégrale caisson Gres Nero vasque Icona
 Miroir / Side
 Lampe / Gordon plafond.

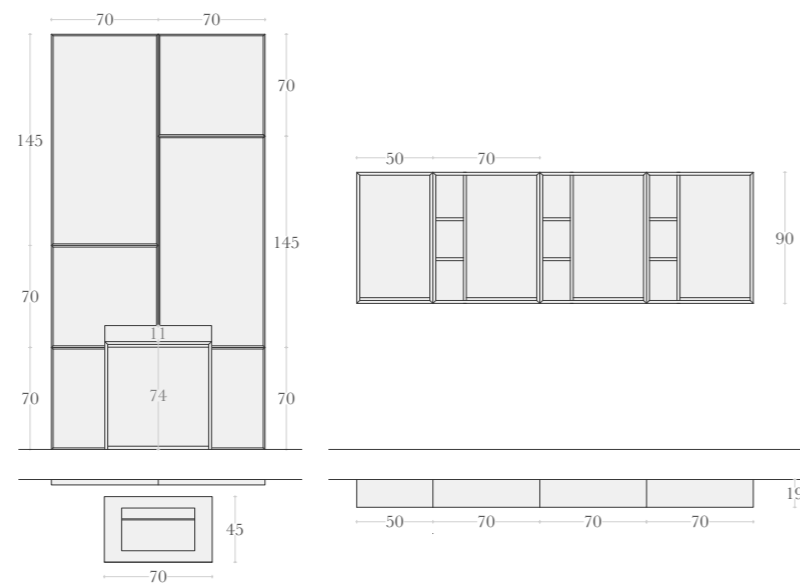







NU_404

Mobile Bagno/Rovere Grey

Boiserie/Side Rovere Grey

Lavabo/ appoggio Domo Marmo Fior di Pesco

Specchio/Soft retroilluminato

Lampada/Nabila sospensione.

^{EN} Bathroom Cabinet/ Rovere Grey
Boiserie/Side Rovere Grey
Washbasin/ Domo Countertop Fior di Pesco Marble
Mirror/ Soft Backlit
Lamp/ Nabila Pendant.
^{DE} Badezimmermöbel/ Rovere Grey
Boiserie/Side Rovere Grey
Waschbecken/ Domo Aufsatz Marmor Fior di Pesco
Spiegel/ Soft Hinterleuchtet
Lampe/ Nabila Pendelleuchte.
^{FR} Meuble Salle de Bain/ Rovere Grey
Boiserie/Side Rovere Grey
Lavabo/ Domo À Poser Marbre Fior di Pesco
Miroir/ Soft Rétroéclairé
Lampe/ Nabila Suspension.

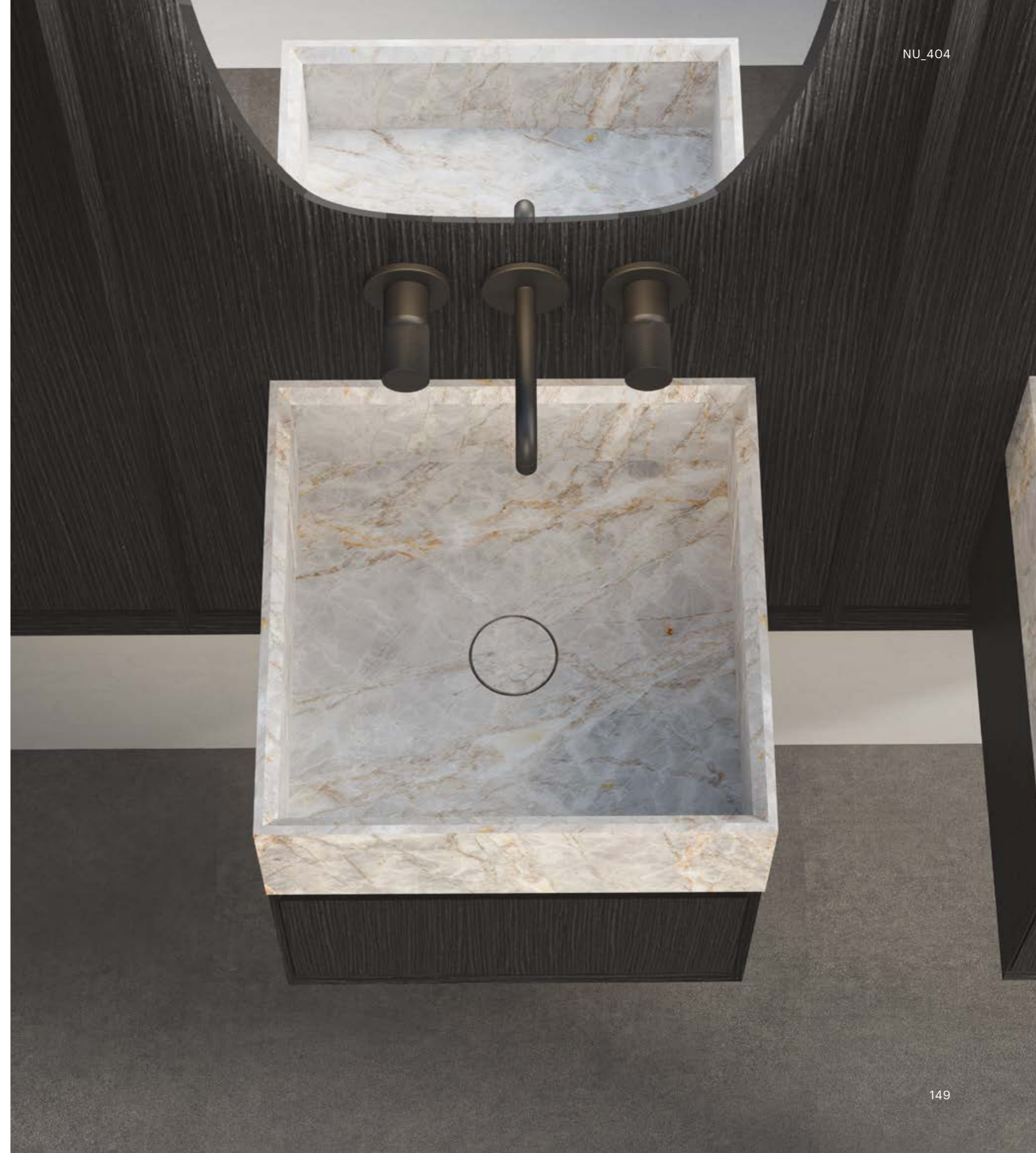
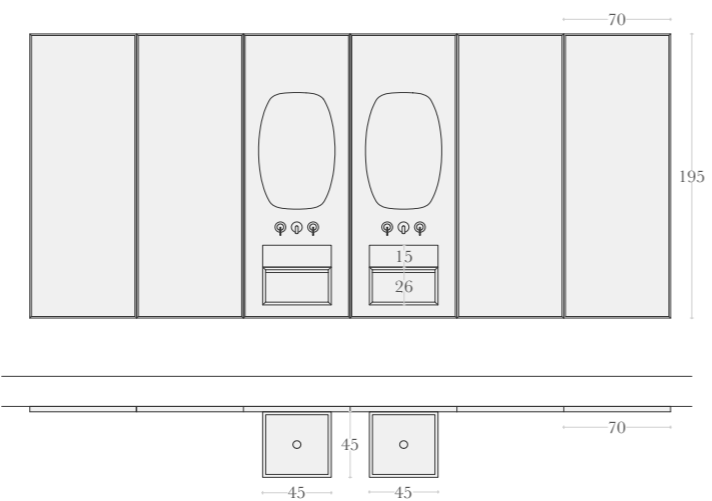





NU_405

Mobile/Rovere Termocotto Naturale
 Frontale Barcode
 Boiserie/Side Rovere Termocotto
 Freestanding/ Wonder Solid Bianco.

^{EN} Cabinet / Rovere Termocotto Naturale
 front Barcode
 Boiserie / Side Rovere Termocotto
 Freestanding / Wonder Solid Bianco.
^{DE} Möbel / Thermobehandelte Eiche Natur
 Front / Barcode
 Boiserie / Side Thermobehandelte Eiche
 Freestanding / Wonder Solid Weiß.
^{FR} Meuble / Chêne Thermotraité Naturel
 Façade / Barcode
 Boiserie / Side Chêne Thermotraité
 Freestanding / Wonder Solid Blanc.

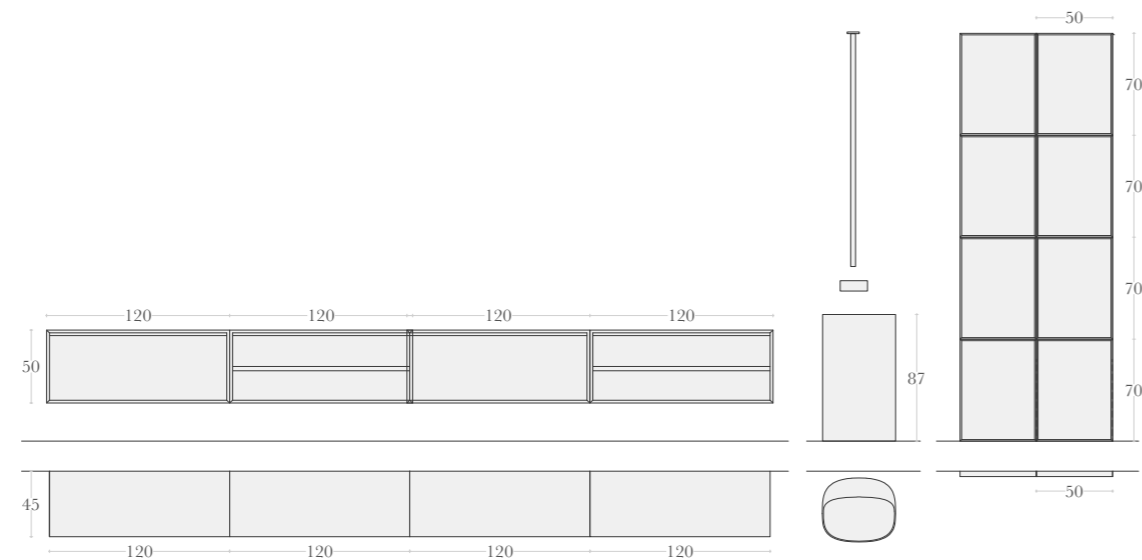





NU_406

Mobile Bagno/Laccato opaco Salice

Top/Piano Solid Color Salice

Lavabo/ Appoggio Round Solid Color Salice

Specchio/Avatar contenitore

Lampada/Riga.

^{EN} Bathroom Cabinet / matt Lacquer Salice

Top / Solid Color Salice top

Washbasin / Round countertop Solid Color Salice

Mirror / Avatar cabinet

Lamp / Riga.

^{DE} Badezimmermöbel / mattlack Salice

Waschtischplatte / Solid Color Salice

Waschbecken / Round Aufsatzbecken Solid Color Salice

Spiegel / Avatar Schrank

Lampe / Riga.

^{FR} Meuble de Salle de Bain / Laqué mat Salice

Plan / Solid Color Salice

Lavabo / Round à poser Solid Color Salice

Miroir / Avatar caisson

Lampe / Riga.

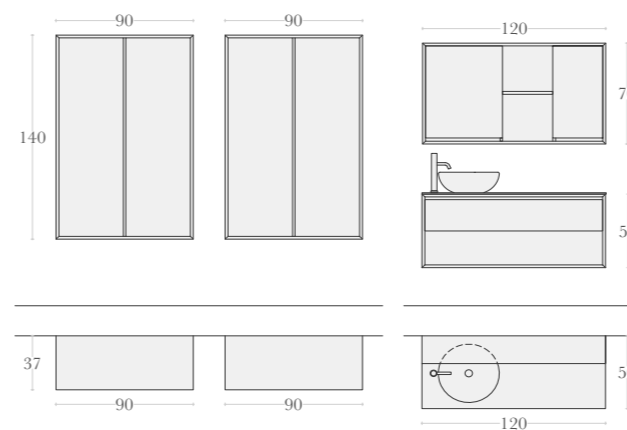





FINITURE LEGNO

EN WOOD FINISHES
DE HOLZBERFLÄCHEN
FR FINITIONS BOIS

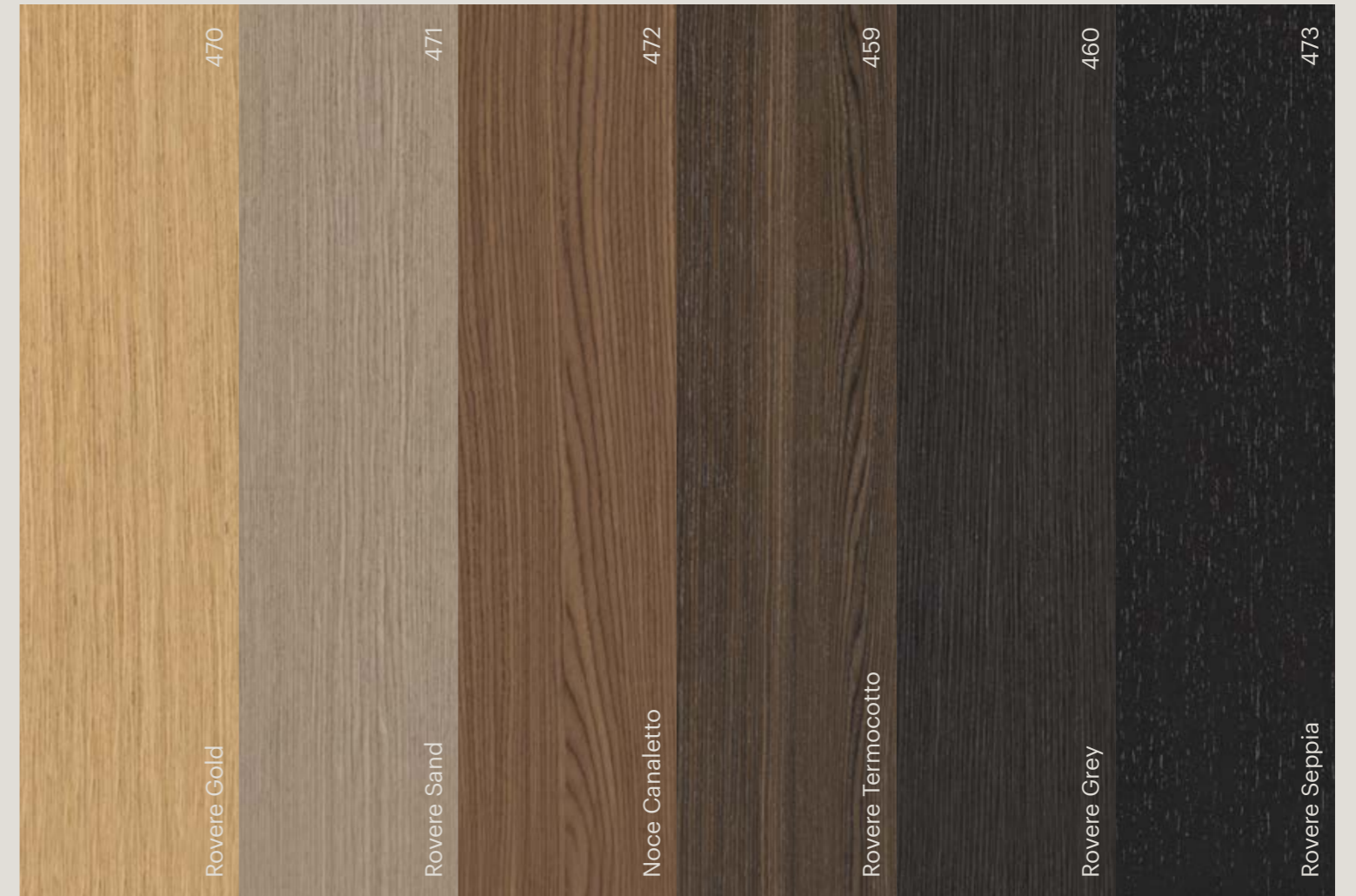

Lucido

300
325
344
378
354
379
356
348
366
387
388
390
389
384
372
365
370

380
381
361
375
382
373
383
371
385
320
386
350
377
351
345
346
315

LACCATI OPACHI E LUCIDI TOP VETRO LUCIDI E SATINATI

EN MATT AND GLOSSY LACQUERS / GLOSSY AND SATIN GLASS TOPS

DE MATT UND GLÄNZEND LACKIERT / GLAS-TOPS GLÄNZEND UND SATINIERT

FR LAQUÉS MATS ET BRILLANTS / PLANS EN VERRE BRILLANTS ET SATINÉS

Opaco

Bianco	0
Pergamon	54
Polvere	430
Grigio Efeso	529
Grigio Medio	254
Grigio Pietra	530
Grigio Piombo	256
Seppia	429
Mimosa	438
Bronzo Testacroce	538
Pan di Spagna	539
Bahia Rosewood	541
Mocha Mousse	540
Mattone	535
Rouille	468
Rosso Vino	265
Laguna	466

Verde Aloe	531
Salvia	532
Verde Oliva	261
Salice	464
Sempreverde	533
Verde Comodoro	512
Verde Narciso	534
Balena	467
Cedar Blue	536
Azzurretto	145
Notturmo	537
Perla	250
Mappamondo	528
Sabbia	251
Creta	431
Malta	432
Cioccolato	143

TOP SOLID BIANCO E COLOR

EN TOP SOLID BIANCO AND COLOR

DE TOP SOLID BIANCO UND COLOR

FR TOP SOLID BIANCO ET COLOR

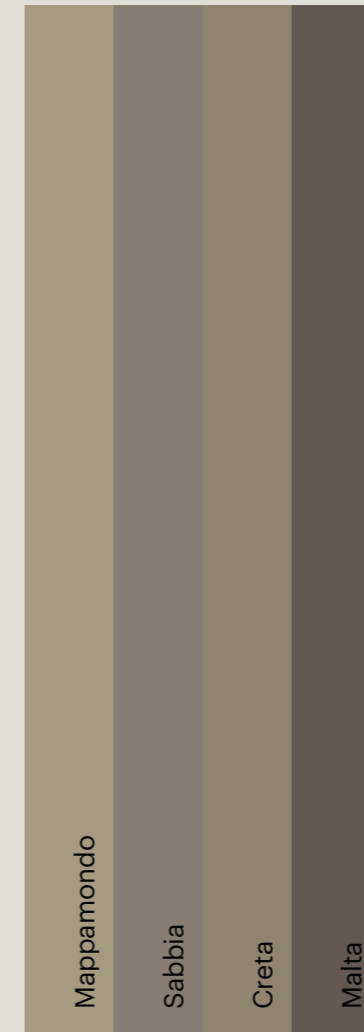
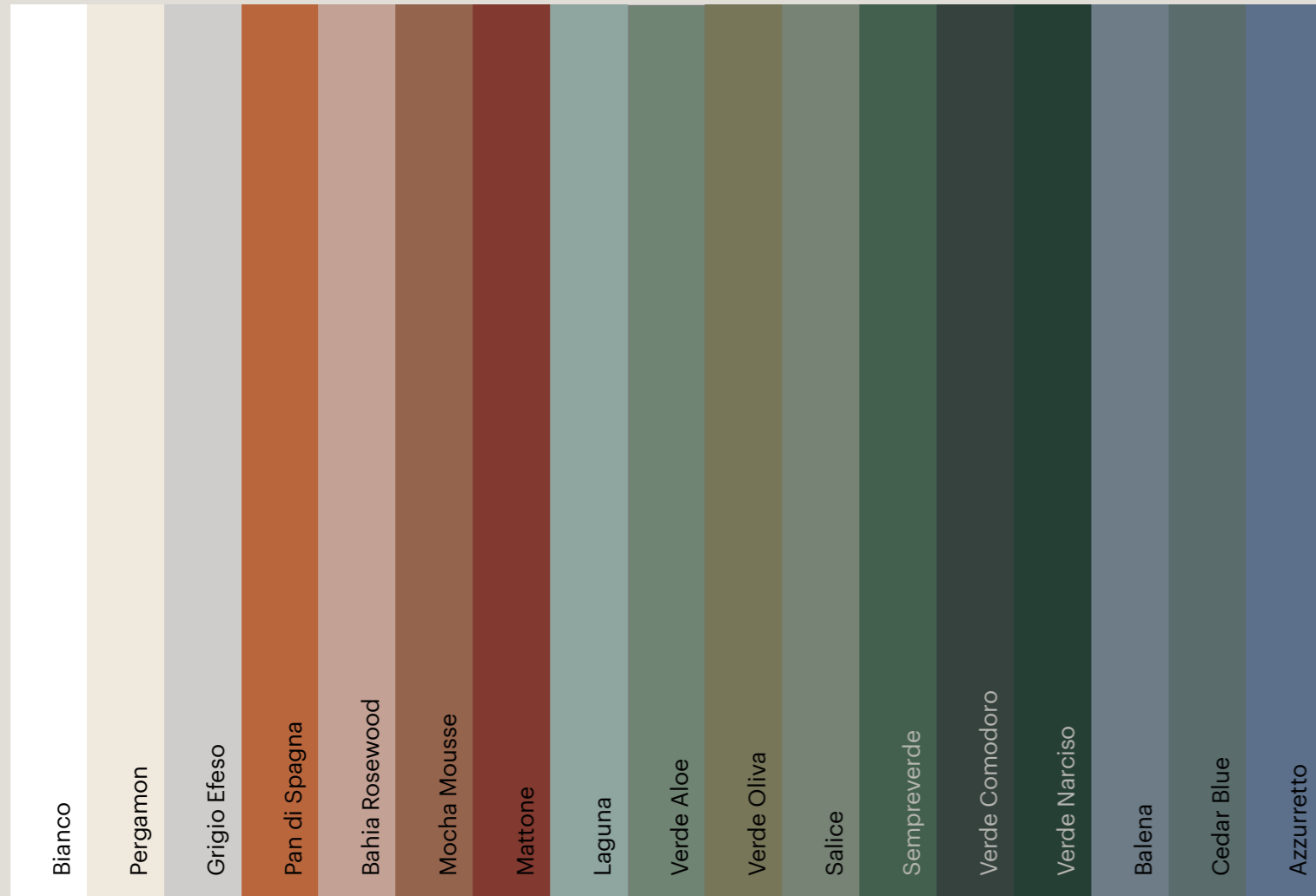

GRES

EN GRES PORCELAIN
DE FEINSTEINZEUG
FR GRÈS CÉRAME



MARMO NATURALE

EN NATURAL MARBLE
DE NATURMARMOR
FR MARBRE NATUREL



VETRO PER RIVESTIMENTO

EN GLASS FOR COVERING
DE GLAS FÜR VERKLEIDUNG
FR VERRE POUR REVÊTEMENT

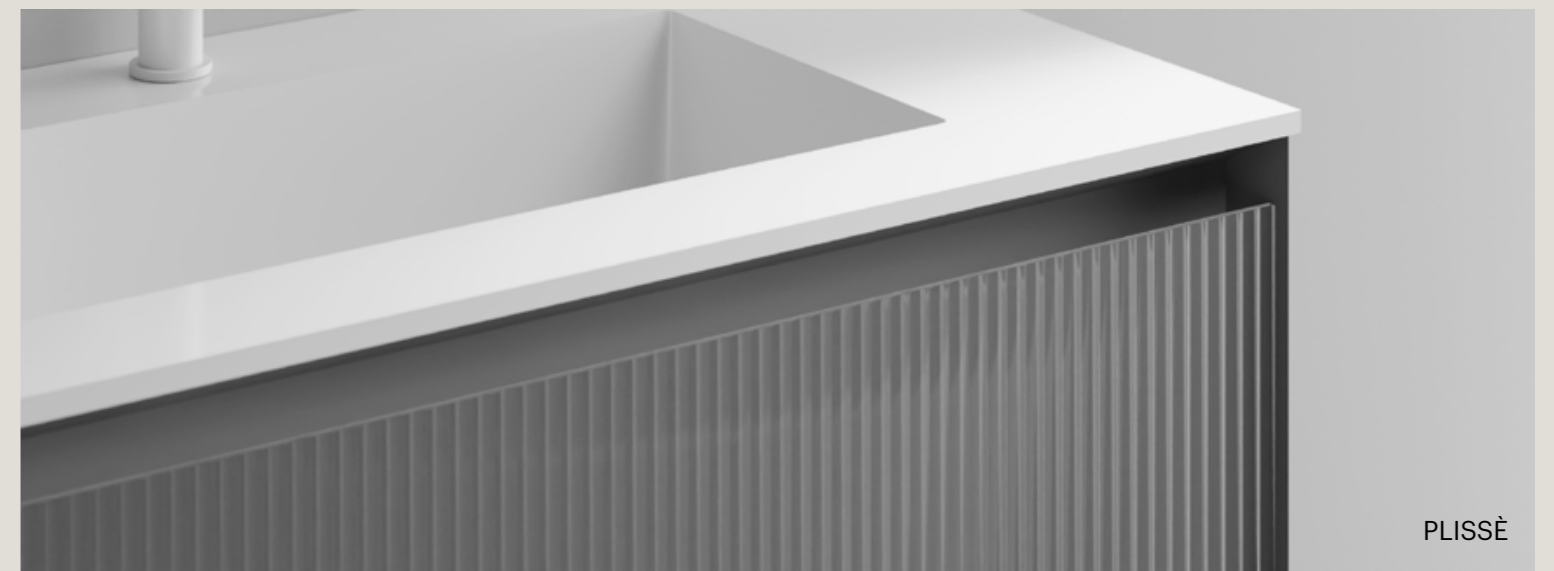
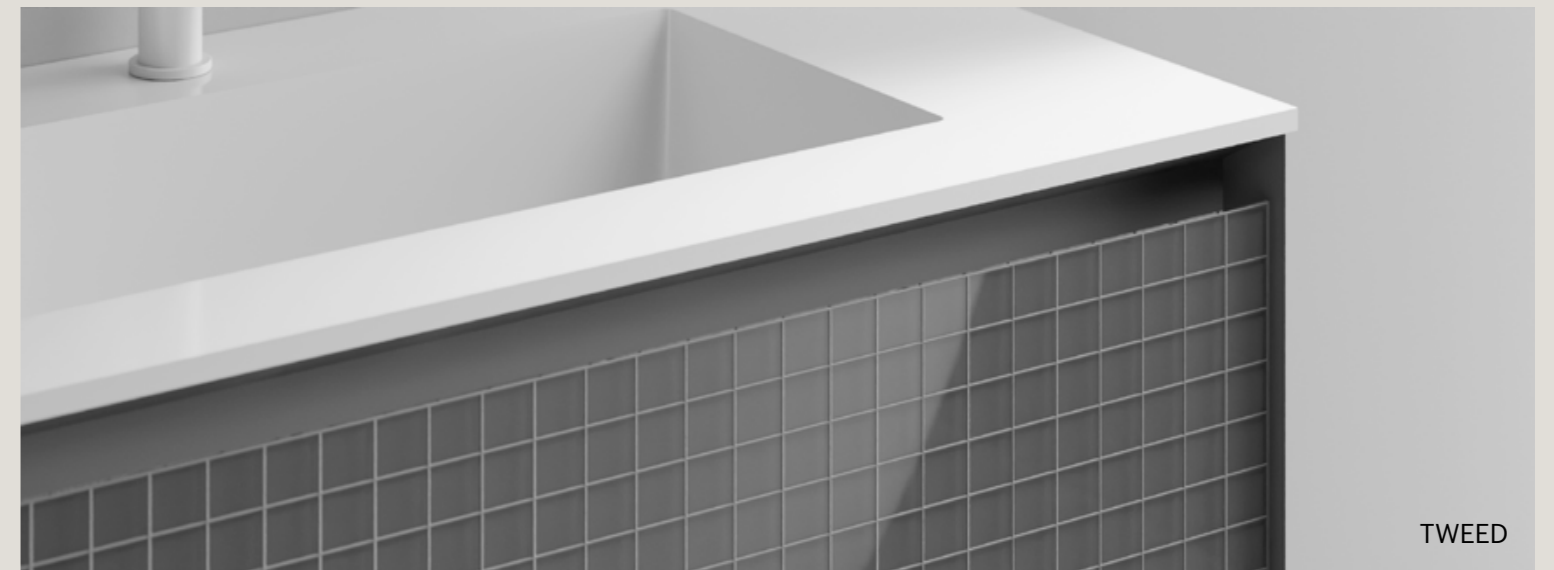
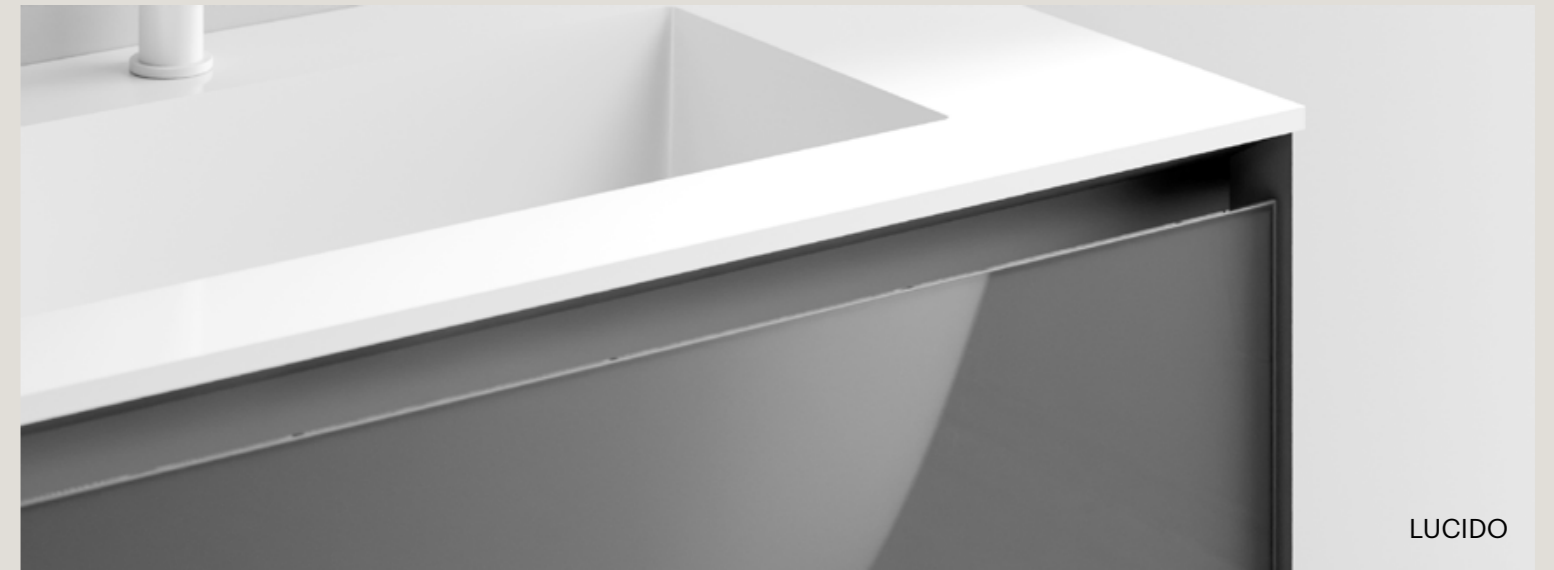
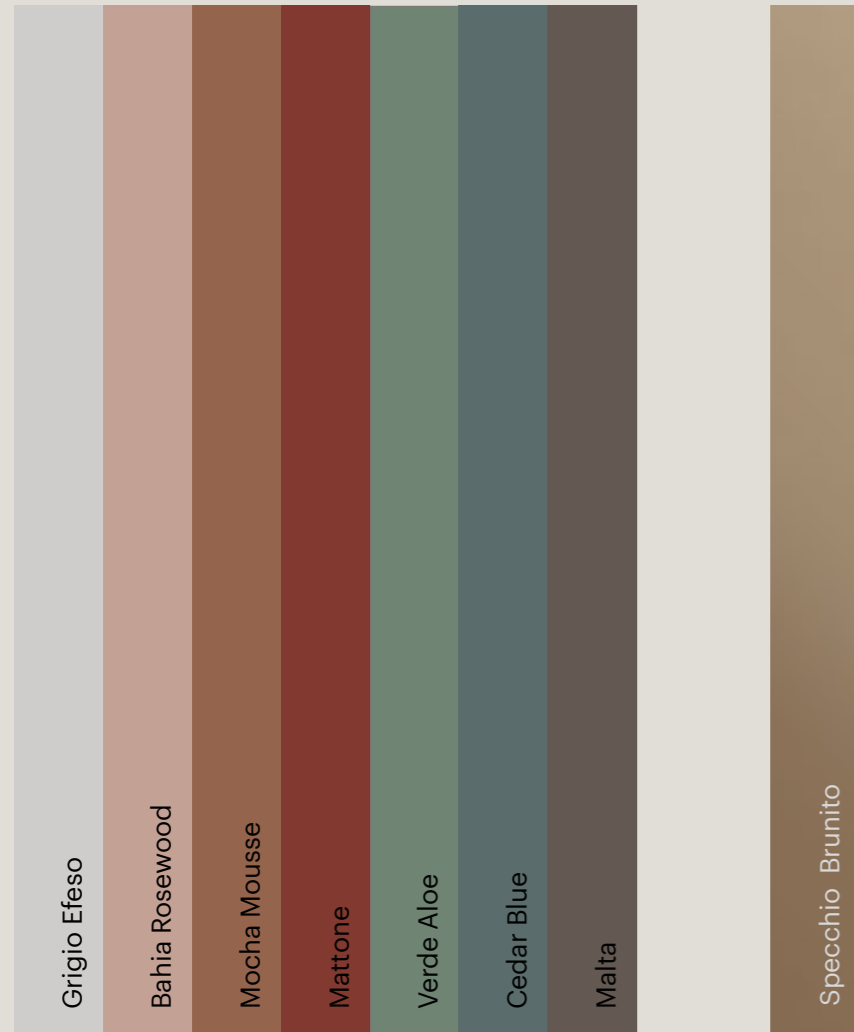

WALLPAPER TWEED

EN WALLPAPER TWEED

DE WALLPAPER TWEED

FR WALLPAPER TWEED



FONDO BIANCO

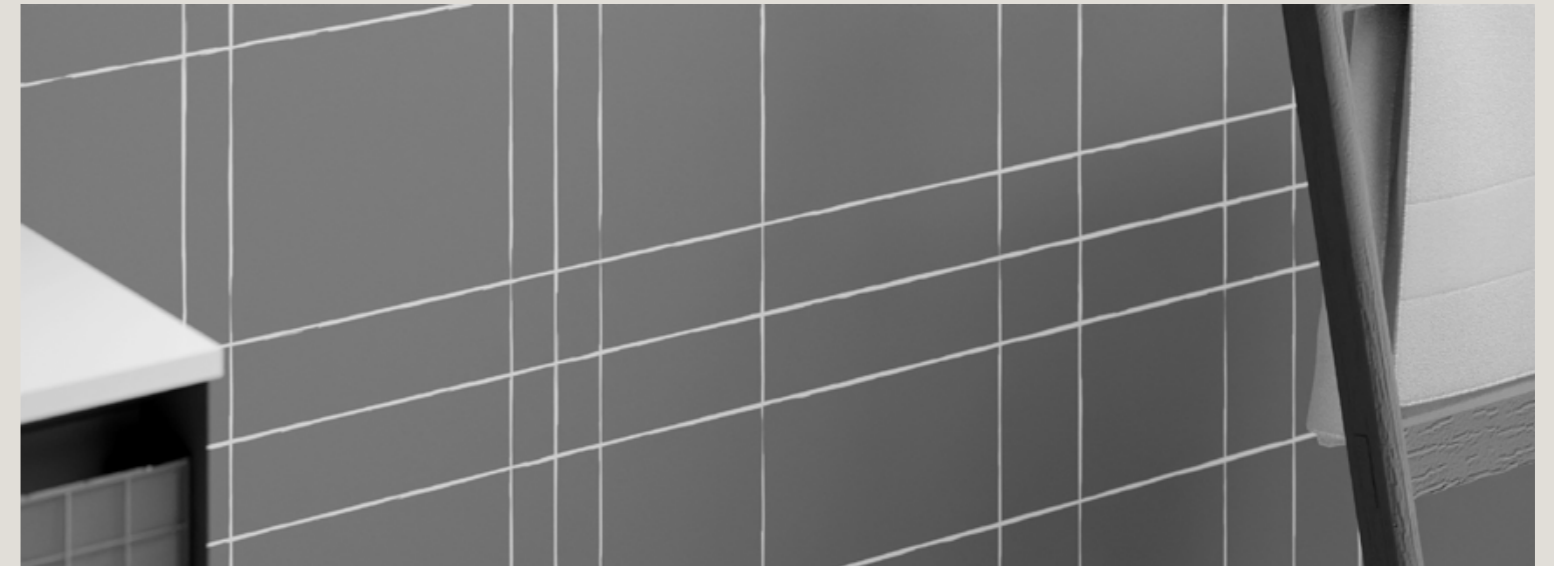

FONDO COLORE

BOISERIE LIGHT



MILLERIGHE



DONEGAL



BARCODE

LA BOISERIE LIGHT È DISPONIBILE NELLE VARIANTI MILLERIGHE, DONEGAL E BARCODE, IN TUTTE LE FINITURE LEGNO.

THE LIGHT BOISERIE IS AVAILABLE IN THE MILLERIGHE, DONEGAL AND BARCODE VARIANTS, IN ALL WOOD FINISHES.

DIE BOISERIE LIGHT IST IN DEN VARIANTEN MILLERIGHE, DONEGAL UND BARCODE IN ALLEN HOLZBERFLÄCHEN ERHÄLTICH.

LA BOISERIE LIGHT EST DISPONIBLE DANS LES VARIANTES MILLERIGHE, DONEGAL ET BARCODE, DANS TOUTES LES FINITIONS BOIS.

BOISERIE MILLERIGHE

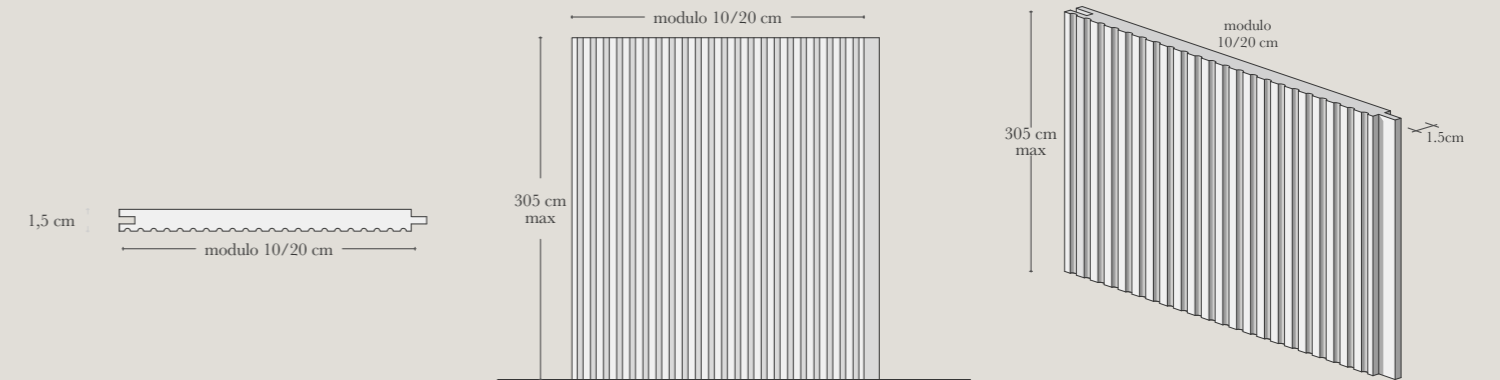

BOISERIE DONEGAL

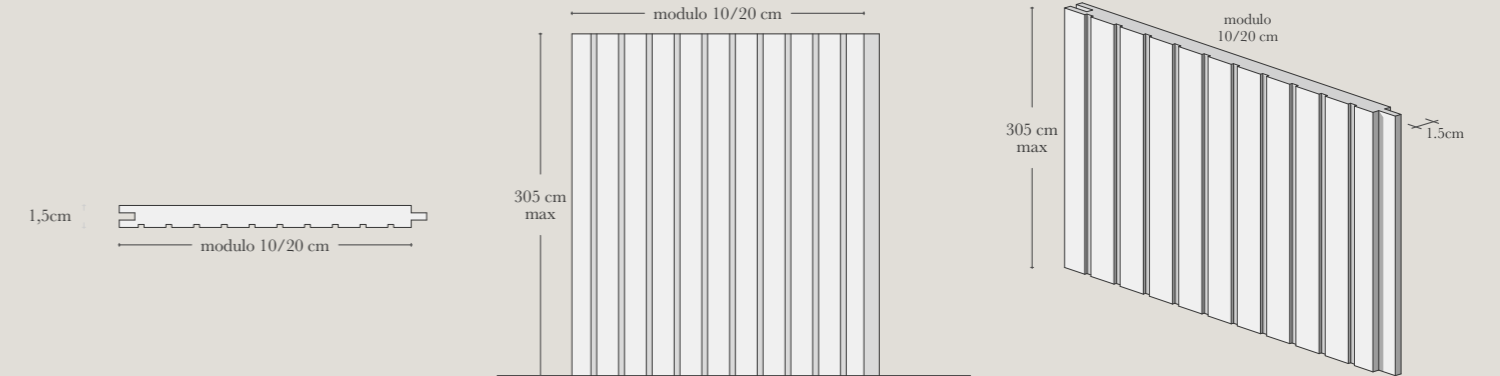

BOISERIE BARCODE

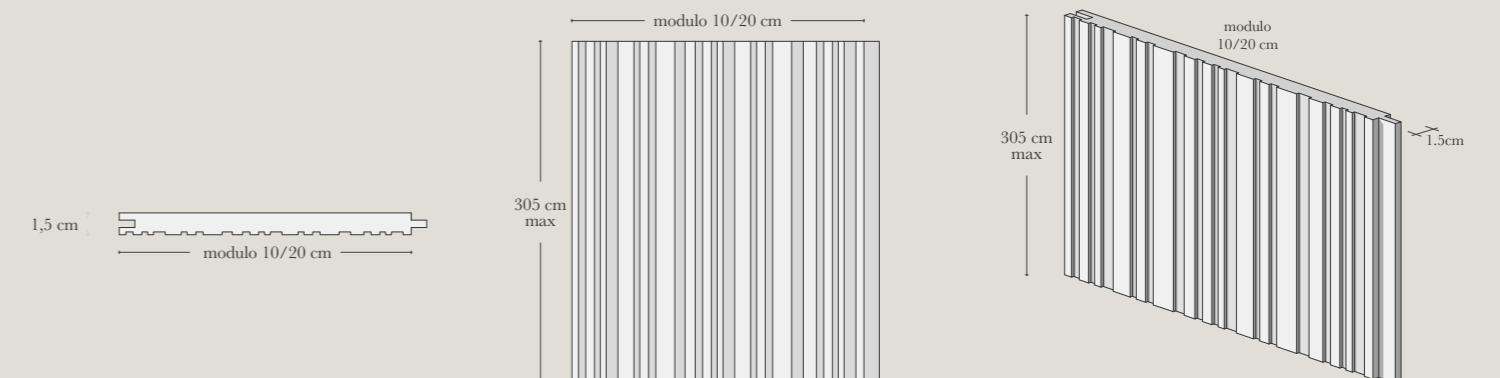

TUTTI I MODULI DELLA BOISERIE LIGHT SONO FORNITI IN LARGHEZZA DI 10/20 CM E ALTEZZA FINO A 305 CM.

ALL LIGHT BOISERIE MODULES ARE SUPPLIED WITH A WIDTH OF 10/20 CM AND A HEIGHT OF UP TO 305 CM.

ALLE MODULE DER BOISERIE LIGHT WERDEN MIT EINER BREITE VON 10/20 CM UND EINER HÖHE VON BIS ZU 305 CM GELIEFERT

TOUTS LES MODULES DE LA BOISERIE LIGHT SONT FOURNIS AVEC UNE LARGEUR DE 10/20 CM ET UNE HAUTEUR ALLANT JUSQU'À 305 CM.

BOISERIE SIDE

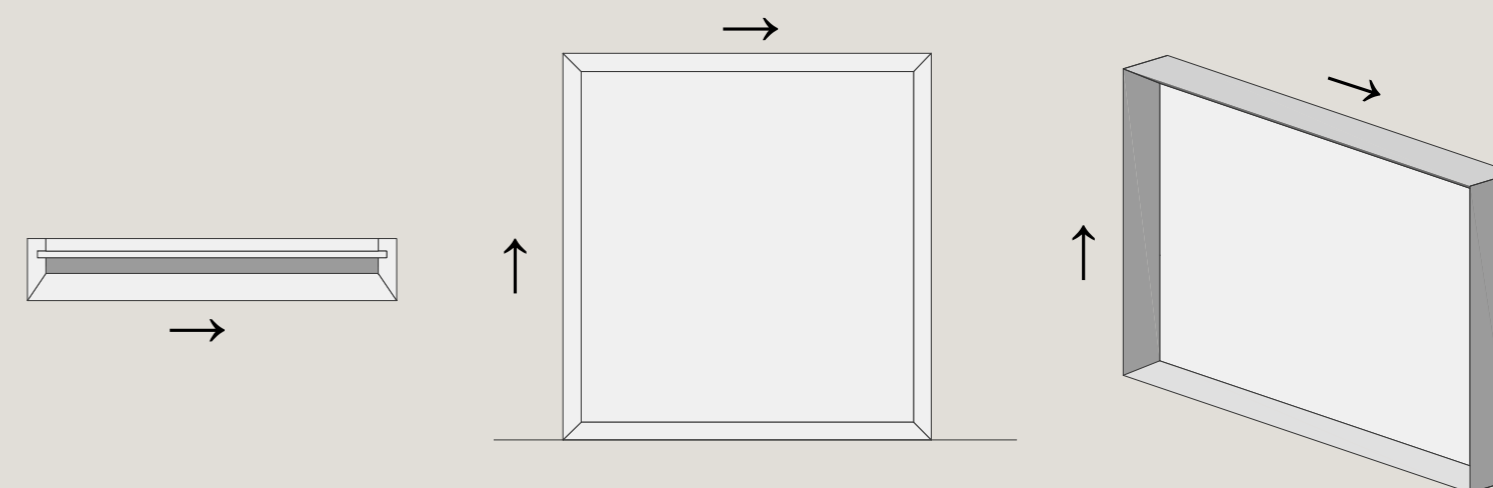

IT - CORNICE REALIZZABILE IN TUTTE LE FINITURE LEGNO.

RIVESTIMENTO FRONTALE DISPONIBILE IN:

- FINITURA LEGNO NATURALE
- FINITURA LEGNO MILLERIGHE DONEGAL O BARCODE
- LACCATO OPACO O LUCIDO
- GRES (DIMENSIONI LIMITATE)
- VETRO (DIMENSIONI LIMITATE).

EN - FRAME AVAILABLE IN ALL WOOD FINISHES.

FRONT COVERING AVAILABLE IN:

- NATURAL WOOD FINISH
- MILLERIGHE, DONEGAL OR BARCODE WOOD FINISH
- MATT OR GLOSSY LACQUER
- STONEWARE (LIMITED SIZES)
- GLASS (LIMITED SIZES).

DE - RAHMEN IN ALLEN HOLZBEREICHEN REALISIERBAR.

FRONTVERKLEIDUNG ERHÄLTICH IN:

- NATURHOLZBEREICHEN
- MILLERIGHE-, DONEGAL- ODER BARCODE-HOLZBEREICHEN
- MATT ODER GLÄNZEND LACKIERT
- FEINSTEINZEUG (BEGRENZTE ABMESSUNGEN)
- GLAS (BEGRENZTE ABMESSUNGEN).

FR - CADRE RÉALISABLE DANS TOUTES LES FINITIONS BOIS.

REVÊTEMENT FRONTAL DISPONIBLE EN :

- FINITION BOIS NATUREL
- FINITION BOIS MILLERIGHE, DONEGAL OU BARCODE
- LAQUÉ MAT OU BRILLANT
- GRÈS CÉRAME (DIMENSIONS LIMITÉES)
- VERRE (DIMENSIONS LIMITÉES).

IT - MODULI DISPONIBILI

EN - AVAILABLE MODULES

DE - VERFÜGBARE MODULE

FR - MODULES DISPONIBLES

↑ 35 → 35 - 50 - 70 - 90 - 120 - 145 - 195

↑ 50 → 35 - 50 - 70 - 90 - 120 - 145 - 195

↑ 70 → 35 - 50 - 70 - 90 - 120 - 145 - 195

↑ 90 → 35 - 50 - 70 - 90 - 120

↑ 120 → 35 - 50 - 70 - 90

↑ 145 → 35 - 50 - 70

↑ 195 → 35 - 50 - 70



**MOBIL
TESINO** | Atelier
dal 1978

DIREZIONE ARTISTICA

Arch. Domenico Sfirro

INTERIOR DESIGNER

Valeria Narcisi

FOTO, RENDERING E ILLUSTRAZIONI

Arch. Gabriele Vacca

GRAPHIC DESIGN

Damco Creativi Digitali

SELEZIONE COLORE E STAMPA

Martintype

RINGRAZIAMENTI:

ILLUMINAZIONE

Tooy

RUBINETTERIE

Fima Carlo Frattini

Mobiltesino S.r.l.

C.da S.Rustico, 33

63065 – Ripatransone (AP)

Italy

**MOBIL
TESTO**